



# BROWN COUNTY RURAL ELECTRICAL ASSOCIATION TECHNICAL SPECIFICATIONS MANUAL

TSM

## Abstract

The Technical Specifications Manual for interconnection of Distributed Energy Resources with Brown County Rural Electrical Association's power system.

# Contents

<b>1.</b>	<b>Introduction</b> .....	<b>1</b>
1.1	General.....	1
1.2	Applicability.....	1
1.3	Solar Systems Less than 40 kW.....	1
1.4	System Operation Type.....	2
1.5	Special Notations.....	2
1.6	Convention for Word Usage.....	2
<b>2.</b>	<b>Abbreviations &amp; Common Terms</b> .....	<b>2</b>
2.1	Abbreviations.....	2
2.2	Key Terms.....	3
<b>3.</b>	<b>**Performance Categories**</b> .....	<b>3</b>
3.1	**Normal – Category A and B**.....	3
3.2	**Assignment of Abnormal Performance Category I, II or III**.....	4
<b>4.</b>	<b>Reactive Power Capability and Voltage/Power Control Performance</b> .....	<b>4</b>
4.1	Constant Power Factor Mode <sup>1</sup> .....	4
4.2	**Voltage and Active Power Mode**.....	4
4.3	**Voltage and Reactive Power Mode**.....	4
<b>5.</b>	<b>Response to Abnormal Conditions</b> .....	<b>4</b>
5.1	Voltage Ride-Through and Tripping <sup>1</sup> .....	5
5.2	Frequency Ride-Through and Tripping <sup>1</sup> .....	5
<b>6.</b>	<b>Protection Requirements</b> .....	<b>6</b>
6.1	Requirement of Utility AC Disconnect <sup>1</sup> .....	6
6.1.1.	Location of Utility AC Disconnection.....	7
6.2	Protection Coordination <sup>1</sup> .....	7
6.2.1.	Secondary Services.....	7
6.2.2.	Primary Services.....	7
6.2.3.	Coordination with Area EPS Automatic Reclosing Schemes.....	7
6.3	Grounded Wye-Wye Protection Requirements <sup>1</sup> .....	8
6.3.1.	General Relay Information.....	8
6.3.2.	Non-Certified Inverters.....	8

6.3.3.	Relaying.....	8
6.3.4.	DC Power for Protection Devices.....	9
6.3.5.	Open Phase Detection .....	9
6.3.6.	Single-phase on Multiphase Services <sup>1)</sup> .....	10
6.4	Interconnection Transformers Connections .....	10
6.4.1	Wye-Wye Transformer Connections .....	10
6.4.2	Wye-Delta Transformer Connections .....	11
6.4.3	Delta-Wye Transformer Connections .....	11
6.5	Grounding.....	11
6.5.1	Requirement of Grounding Transformer .....	11
6.5.2	Wye-Wye Interconnection.....	11
6.5.3	Wye-Delta Interconnection .....	11
6.5.4	Delta-Wye Interconnection .....	11
<b>7.</b>	<b>Operations .....</b>	<b>11</b>
7.1	Periodical Testing & Record Keeping .....	11
7.2	O&M Agreements .....	12
7.3	System Voltage.....	13
7.4	Power Ramp Rates .....	13
7.4.1	Overview .....	13
7.4.2	Power Ramp Rates Requirements .....	14
7.5	Enter Service.....	14
7.5.1	DER without ESS.....	14
7.5.2	Energy Storage Systems.....	15
<b>8.</b>	<b>Power Control Systems .....</b>	<b>15</b>
8.1	General.....	15
8.2	Power Control System Requirements .....	15
8.3	Documentation .....	15
8.4	Inadvertent Export .....	16
<b>9.</b>	<b>Interoperability .....</b>	<b>16</b>
9.1	Overview .....	16
9.2	Sales to Parties Other Than the Area EPS Operator .....	17
9.3	Level of Communication Required.....	17
9.4	Level of Monitoring and Control Required .....	17

9.5	Security.....	18
9.5.1	Physical and Front Panel.....	18
9.5.2	Network Security .....	18
9.5.3	Local DER Communication Interface Security .....	19
<b>10.</b>	<b>Energy Storage Systems.....</b>	<b>19</b>
10.1	Grid Support Functions .....	19
10.2	Common Modes of Operation .....	19
10.3	Enter Service.....	19
10.4	Modification of Control Modes.....	19
<b>11.</b>	<b>Metering Requirements<sup>n</sup>.....</b>	<b>20</b>
11.1	DER Interconnection on Services with Subtractive Metering.....	20
11.2	Metering Required for DER Installation.....	20
11.3	Production Meter Requirement.....	21
11.3.1	DER Systems with ESS .....	21
11.3.2	Extended Parallel DER Interconnections .....	21
11.3.3	All Other DER Interconnections .....	21
11.4	Acceptable Metering.....	21
11.4.1	Meter Sockets .....	21
11.4.2	Location and Accessibility .....	22
11.5	Type of Metering Configurations .....	22
<b>12.</b>	<b>Signage and Labeling<sup>n</sup> .....</b>	<b>22</b>
12.1	General Requirements .....	22
12.2	Utility AC Disconnect.....	22
12.2.1	Multiple AC Disconnects.....	22
12.3	Production Meter.....	22
<b>13.</b>	<b>Test and Verification Requirement<sup>n</sup>.....</b>	<b>23</b>
13.1	Applicability.....	23
13.2	Certified DER Systems .....	23
13.3	Non-Certified DER Systems .....	23
13.4	Pre-Energization Testing – Interconnection Customer.....	23
13.5	Energization Testing Criteria .....	25
13.5.1	Installation Verification.....	25
13.5.2	Anti-Islanding Test .....	25

13.5.3	Additional Onsite Testing.....	26
13.6	Periodic Testing and Documentation.....	26
13.6.1	Battery Documentation .....	26
13.7	Failure Protocol .....	26
13.8	Modification to Existing DER.....	27
<b>14.</b>	<b>Sample Documents for Simplified Process .....</b>	<b>27</b>
14.1	Introduction.....	27
14.2	One-Line Diagram.....	27
14.3	Site Diagram .....	28
14.4	Testing Procedure .....	30
<b>Appendix A – Types of Interconnection.....</b>		<b>31</b>
<b>Appendix B – Relay Functions .....</b>		<b>41</b>
<b>Appendix C – Types of ESS Control Modes.....</b>		<b>44</b>
<b>Appendix D – Example Diagrams.....</b>		<b>47</b>
<b>Appendix E – Example Simplified Process DER Testing Procedure .....</b>		<b>51</b>
<b>Appendix F – DER Alteration Notification .....</b>		<b>53</b>
<i>Table 1 – Synchronous DER Response (shall trip) to Abnormal Voltages .....</i>		<i>4</i>
<i>Table 2 – Synchronous DER Response (shall trip) to Abnormal Voltages .....</i>		<i>5</i>
<i>Table 3 – Inverter DER Response (shall trip) to Abnormal Voltages .....</i>		<i>5</i>
<i>Table 4 – DER Response (shall trip) to Abnormal Frequencies .....</i>		<i>5</i>
<i>Table 5 – DER Enter Service Criteria Ranges .....</i>		<i>14</i>
<i>Table 6 – Monitoring and Control Requirements for DER Systems .....</i>		<i>17</i>
<i>Table 7 – Summary of Relaying Requirements .....</i>		<i>43</i>

**Revision History**

Date	Version	Effective Date	Comments
5/21/2020	1.0	7/1/2020	Initial Date
9/1/2022	1.1	9/15/22	Modification to one-line diagrams

# 1. Introduction

## 1.1 General

The State of Minnesota has adopted technical interconnection and interoperability requirements for distributed energy resources interconnected to the distribution system. These overarching requirements are documented in what is commonly referred to as the State of Minnesota TIIR. This document, the Technical Specification Manual, also referred to as the TSM, is an accompanying document to the TIIR. The TSM will contain additional technical requirements specific to the Area EPS Operator.

Both the TIIR and the TSM are to be used with the adopted interconnection process. For cooperatives electric associations in Minnesota, the interconnection process is known as the Cooperative Minnesota DER Interconnection Process or C-MIP. Proposed DER interconnections submitted under the C-MIP process shall be designed to comply with the technical requirements listed in the TIIR and Area EPS Operator's TSM.

The TSM is expected to be updated on a regular basis as DER technology and interconnection standards change. Interconnection Customers should confirm they are using the latest TSM version when designing their DER system. This TSM version incorporates the interim technical guidance listed in Annex C of the TIIR.

Substantial changes to existing DER systems, such as capacity additions or inverter changes, are required to be compliant with the latest version of the TIIR and TSM.

## 1.2 Applicability

The TSM document is designed to provide technical requirements for renewable, storage and fossil fuel DER systems specific to the Area EPS Operator. The wide-ranging type of DER systems addressed in the TSM at times may be classified by their certification, or lack thereof, to IEEE 1547-2018. In other locations in the TSM, the DER system may be classified as how the DER system operates with the Area EPS (also known as the utility's distribution system.) The size of the DER system only will affect the type of metering, monitoring and control requirements will be required by the Area EPS Operator.

## 1.3 Solar Systems Less than 40 kW

The majority of the DER interconnection applications the Area EPS Operator receives are sized less than 40 kW and are solar systems with certified inverters. While the entire TSM document applies to all DER systems, solar systems sized less than 40 kW should focus on meeting the requirements of the following sections:

- Section 4.1 – Constant Power Factor Mode
- Section 5.1 and 5.2 – Response to Abnormal Conditions
- Section 6.1, 6.2 and 6.3.6 – Protection Requirements

- Section 11 – Metering Requirements
- Section 12 – Signage and Labeling
- Section 13 – Test and Verification Requirement

These sections have been identified by a  $\eta$  at the section header.

#### 1.4 System Operation Type

The TSM addresses different types of DER systems by the way the DER system operates with the Area EPS. Additional information of the different types is available in the Appendix A.

#### 1.5 Special Notations

Portions of the TSM are not currently enforced by the Area EPS Operator unless mutual agreement between the DER owner and the Area EPS Operator is reached. These sections are noted by the section title proceeded and followed by asterisks (\*\*). These sections will not be enforced until the Minnesota Public Utilities Commission determining certified equipment is readily available. The text under these sections will be *grayed out*.

Sections of the TSM that are *italicized* are noting the text is directly from the TIIR.

#### 1.6 Convention for Word Usage

Throughout this document, the word *shall* is used to indicate a mandatory requirement. The word *should* is used to indicate a recommendation. The word *may* is used to indicate a permissible action. The word *can* is used for statements of capability and possibility.

## 2. Abbreviations & Common Terms

### 2.1 Abbreviations

<b>AGIR</b>	Authority Governing Interconnection Requirements
<b>Area EPS Operator</b>	The utility that operated the distribution system. In this document the Area EPS Operator is Brown County Rural Electrical Association.
<b>BPS</b>	Bulk Power System
<b>DER</b>	Distributed Energy Resource
<b>C-MIP</b>	Cooperative Minnesota DER Interconnection Process
<b>EPS</b>	Electric Power System
<b>ESS</b>	Energy Storage System
<b>PoC</b>	Point of Distributed Energy Resource Connection
<b>PCC</b>	Point of Common Coupling
<b>RPA</b>	Reference Point of Applicability
<b>RTO</b>	Regional Transmission Operator

<b>MN DER TIIR</b>	Minnesota Distributed Energy Resource Technical Interconnection and Interoperability Requirements
<b>TPS</b>	Transmission Power System
<b>TSM</b>	Technical Specifications Manual

## 2.2 Key Terms

The terms used in this document are defined in the MN DER TIIR. For quick reference, the key terms are defined in this section.

**Area Electric Power System (Area EPS):** *The electric power distribution system connected at the Point of Common Coupling.*

**Area Electric Power System Operator (Area EPS Operator):** *An entity that owns, controls, or operates the electric power distribution system that are used for the provision of electric service.*

**Local Electric Power System (Local EPS):** *An EPS contained entirely within a single premise or group of premises.*

**Point of Common Coupling (PCC):** *The point of connection between the Area EPS and the Local EPS.*

**Point of Distributed Energy Resources Connection (PoC):** *The point where a DER unit is electrically connected in a Local EPS and meets the requirement of the MN DER TIIR and this document exclusive of any load present in the respective part of the Local EPS.*

**Power Control:** *System that controls the output (production or discharging) and input (charging) of one or more DER in order to limit output, input, export and/or import.*

**Reference Point of Applicability (RPA):** *The location where the interconnection and interoperability performance requirements specified in the MN DER TIIR and this document apply.*

## 3. **\*\*Performance Categories\*\***

The Area EPS Operator has no further requirements for performance categories than that provided in the MN DER TIIR at this time. Performance Category Assignment is currently not enforced unless mutual agreement between the Area EPS Operator and Interconnection Customer is reached.

### 3.1 **\*\*Normal – Category A and B\*\***

The Area EPS Operator currently follows the TIIR for category assignment.



### 3.2 **\*\*Assignment of Abnormal Performance Category I, II or III\*\***

The Area EPS Operator currently follows the TIIR for abnormal performance categories.

## 4. **Reactive Power Capability and Voltage/Power Control Performance**

The DER shall be capable of providing the necessary power factor to help mitigate the impact of the DER on the grid. This section provides the default and expected capabilities of a DER system on the Area EPS system.

### 4.1 **Constant Power Factor Mode<sup>1</sup>**

The voltage and reactive power control for a DER system will greatly depend on the size and location of the DER within the Area EPS. The Area EPS Operator expects that the DER system shall maintain a steady PF at the PCC. The Area EPS Operator's default settings for power factor control shall be as shown in Table 1.

*Table 1 – Synchronous DER Response (shall trip) to Abnormal Voltages*

<b>DER System (kVA AC)</b>	<b>Power Factor</b>	<b>Reactive Power Control</b>
< 40 kVA	0.98	Absorbing Reactive Power
40 kVA to < 250 kVA	0.98	Absorbing Reactive Power
250 kVA to < 5 MVA	0.98*	Absorbing Reactive Power
5 MVA to 10 MVA	0.98*	Absorbing/Providing Active Power

\*Systems shall be capable of being adjusted within the range of 0.95 to 1.0 PF

During normal operation of the DER system the power factor shall never be below 0.90 at the RPA.

### 4.2 **\*\*Voltage and Active Power Mode\*\***

The Area EPS Operator requires the settings for Voltage and Active Power control to be disabled.

### 4.3 **\*\*Voltage and Reactive Power Mode\*\***

The Area EPS Operator requires the settings for Volt-Var control to be disabled.

## 5. **Response to Abnormal Conditions**

At this time, all DER systems are required to disconnect from the Area EPS when the Area EPS experiences abnormal frequency or voltage to avoid unintentional islanding. All DER systems shall trip for any abnormal voltage or abnormal frequency with clearing times as stated in the following sections.

### 5.1 Voltage Ride-Through and Tripping<sup>1</sup>

The DER shall trip for any abnormal voltage. The Table 2 and Table 3 list the maximum clearing time for the DER system upon the occurrence of abnormal voltage levels.

*Table 2 – Synchronous DER Response (shall trip) to Abnormal Voltages*

Shall Trip – Synchronous DER		
Shall Trip Function	Default Setting	
	Clearing time (s)	Voltage (per unit of nominal voltage)
UV2	0.16	0.50
UV1	2.0	0.88
OV1	1.0	1.10
OV2	0.16	1.20

*Table 3 – Inverter DER Response (shall trip) to Abnormal Voltages*

Shall Trip – Inverter DER		
Shall Trip Function	Default Setting	
	Clearing time (s)	Voltage (per unit of nominal voltage)
UV2	0.16	0.50
UV1	2.0	0.88
OV1	1.0	1.10
OV2	0.16	1.20

No advanced voltage ride through is allowed. Future technology and situations may allow DER operations to ride-through some voltage flickers and not require the DER system to go offline, however at this time all DER systems shall be required to disconnect and reconnect for all abnormal voltage occurrences.

### 5.2 Frequency Ride-Through and Tripping<sup>1</sup>

The DER shall trip for any abnormal frequency. The following table list the maximum clearing time for the DER system upon the occurrence of abnormal frequency.

*Table 4 – DER Response (shall trip) to Abnormal Frequencies*

Shall Trip Function	Default Setting	
	Clearing time (s)	Frequency (Hz)
UF1	0.16	59.3
OF1	0.16	60.5

No advanced frequency ride through is allowed. Future technology and situations may allow DER operations to ride-through some frequency flickers and not require the DER system to go offline, however at this time all DER systems shall be required to disconnect and reconnect for all abnormal frequency occurrences.

## 6. Protection Requirements

Protective devices are required to permit safe and proper operation of the Area EPS while interconnected with DER systems. Examples of the protection requirements for different types of DER interconnections are shown in Appendix A. The figures in Appendix A are for typical installations and may not fit all possible configurations. The specific protection requirements for interconnection will depend upon the DER's size and type; the number of units; Area EPS configuration and characteristics; the operating modes of the DER; and the location of the proposed DER interconnection on the Area EPS.

An increased degree of protection is required for increased DER size. As DER capacity size increases the greater magnitude of short circuit currents and the potential impact to system stability can occur from the DER installations. Medium and large DER systems will require more sensitive and faster protection to minimize damage and ensure safety.

The interconnection of a new DER facility to the Area EPS shall not degrade any of the existing Area EPS protection and control schemes nor lower the existing levels of safety and reliability to other entities interconnected as loads to the Area EPS.

The Interconnection Customer shall provide protective devices and systems to detect the voltage, frequency and harmonic levels as defined in the IEEE 1547 during periods when the DER is operated in parallel with the Area EPS. The Interconnection Customer shall be responsible for the purchase, installation, and maintenance of these devices.

### 6.1 Requirement of Utility AC Disconnect<sup>1</sup>

A Utility AC Disconnect furnished by the Interconnection Customer is required on all DER systems to safely isolate the DER from the Area EPS. The disconnect shall:

- Provide a visible air-gap.
- Be an AC rated device, UL or National Electrical Manufacture's Association approved.
- Be manually operable by one person.
- Be lockable in the open position.
- Be sized for adequate ampere capacity.
- Be continuously readily accessible, with unescorted access to the Area EPS Operator's personnel.
- Does not require fasteners to be removed to access the disconnect handle.
- Be gang operated so that operation of one switch handle opens and closes all energized conductors simultaneously.
- Not interrupt neutral conductors.

The Utility AC Disconnect may be the same disconnecting means required by the NEC 690.13, 705.20 or 706.15 if the disconnect meets all the other Area EPS Operator requirements listed in this section.

#### **6.1.1. Location of Utility AC Disconnection**

The Utility AC disconnect used by the Area EPS Operator to safely isolate the DER from the Area EPS shall be located within 10 feet of the revenue meter.

### **6.2 Protection Coordination<sup>1</sup>**

#### **6.2.1. Secondary Services**

In general, overcurrent protection requirements shall meet the requirements of the NEC for DER interconnection that occur behind the Area EPS Operator's revenue meter. All electric services are required to have main service protection furnished by the customer immediately after the main service meter. Double-lugged meters shall have overcurrent interrupting protection on both sets of conductors immediately after the revenue meter.

#### **6.2.2. Primary Services**

The first protective device on the DER customer's side of the revenue meter shall coordinate with the Area EPS Operator's protective device. Protection coordination studies are required for interconnections to the primary system. The protection study shall be completed by the Interconnection Customer and reviewed and approved by the Area EPS Operator prior to interconnection and energization.

#### **6.2.3. Coordination with Area EPS Automatic Reclosing Schemes**

The Area EPS Operator may have automatic reclosing schemes designed into the Area EPS to attempt to prevent transient faults from becoming a long-term outage. The automatic reclosing scheme will de-energize a portion of the Area EPS and re-energize the same section of Area EPS in a short period of time, less than one second, often clearing the fault on the Area EPS.

Automatic reclosing on the Area EPS can potentially damage rotating DER generation, both synchronous and induction DER generators, operating in parallel with the Area EPS. The addition of DER shall not alter the standard auto restoration schemes designed in the Area EPS. The Interconnection Customer is responsible for protecting the DER facility's equipment from damage due to the automatic or manual reclosing, faults or other disturbances on the Area EPS.

### **6.3 Grounded Wye-Wye Protection Requirements<sup>1</sup>**

The following protection requirements are for grounded wye-wye DER system interconnections. Additional protection requirements may apply for DER systems which are not grounded wye-wye or do not utilize a grounded wye-wye transformer as part of the DER interconnection system design. Non-exporting DER systems that operate in parallel with the Area EPS have the same requirements as that of any other DER interconnection.

#### **6.3.1. General Relay Information**

For DER systems which are smaller than 250 kW and utilize a certified inverter(s) for interconnection, a Professional Electrical Engineer is not required to review, test and approve the protective functions or settings of the inverter. For all other DER systems to be interconnected with Area EPS, the protective functions and relay setting shall be reviewed and approved by a Professional Electrical Engineer registered in the State of Minnesota.

Prior to energization or interconnection of the DER with the Area EPS, a copy of the proposed protective relay settings shall be supplied to the Area EPS Operator for review and approval. The Area EPS Operator shall review the protective relay settings to ensure proper coordination between the DER and the Area EPS. The proposed protective relay settings shall be provided to the Area EPS Operator with time allotted to allow for review, coordination, implementation and functional testing of the protective system including any requested modifications.

#### **6.3.2. Non-Certified Inverters**

The use of inverters that have not been tested by a Nationally Recognized Testing Laboratory (NRTL) and certified to meet the UL 1741 performance requirements are not allowed by the Area EPS Operator as an acceptable design of the DER system.

#### **6.3.3. Relaying**

All equipment providing relaying functions shall meet or exceed ANSI/IEEE Standards for protective relays, i.e., C37.90, C37.90.1 and C37.90.2.

Required relays that are not “draw-out” cased relays shall have test plugs or test switches installed to permit field testing and maintenance of the relay without unwiring or disassembling the equipment.

Three-phase interconnections shall utilize three-phase power relays, which monitor all three phases of voltage and current, unless so noted in the Appendix A diagrams.

All protective relays must have DC power supplies powered by station class batteries and charging system. The battery system shall be equipped with a DC-undervoltage detection alarm or be monitored by a continuous monitoring facility. For DER larger than 250 kW, the DC voltage level must be provided to the Area EPS Operator's SCADA system. See Section 9 for further information.

All relays shall be equipped with setting limit ranges at least as wide as specified in IEEE 1547, and meet other requirements as specified in the Area EPS interconnect study. Setting limit ranges are not to be confused with the actual relay settings required for the proper operation of the installation. At a minimum, all protective systems shall meet the requirements established in IEEE 1547.

See Appendix B for specific information regarding the types of relaying.

#### **6.3.4. DC Power for Protection Devices**

All relays and other devices which require external power to operate must be supplied by a DC battery system that can maintain power to the protective device for a minimum of 8 hours during a complete power outage. The DC battery charger shall be able to be powered by the DER if power from the Area EPS is lost. The DER shall be blocked from reconnecting to the Area EPS if the adequate DC power is not available to the protective devices.

The DC battery system shall be capable of monitoring and alarming for certain conditions related to voltage levels and charging ability. The DC battery system shall be monitored for DC voltage levels and have the capability of alarming if DC voltage reaches levels that cannot allow operation. The DC battery system shall also alarm if the battery charging system fails.

The alarms from the DC battery system shall be monitored by the Interconnection Customer. If the alarms are not monitored continuously, the alarm shall be audible or include a flashing light before complete loss of DC battery voltage.

#### **6.3.5. Open Phase Detection**

For non-inverter based DER, or inverter-based DER that opt not to use the onboard protective functions of the inverter for open-phase detection, either due to DER design configurations that render the detection method invalid or other reason, special consideration will need to be given to the methodology used to detect and trip for an open phase event.

Typical inverter-based configurations that require additional relaying include:

- Configurations with zig-zag or grounded wye-delta grounding banks.
- Configurations with delta windings on onsite transformers.

As required by IEEE 1547, all DER are must detect open phase conditions at their RPA when their output is as low as 5% of their rated output, or, if not capable of producing apparent power at 5% of its rated output, at the lowest output the DER can continue producing apparent power.

The Area EPS Operator does not recommend a specific method for detecting an open phase condition, as there are many acceptable achievement methods. Positive-sequence phase balance, zero-sequence detection and undervoltage relaying are known to be deficient protective schemes and will not be accepted for the purpose of detecting and tripping of an open phase.

- Positive-sequence phase balance and zero-sequence detection must set their pickup levels above the inherit imbalance on the Area EPS to avoid nuisance tripping. This pickup level will often be too high to allow the protective system to identify an open phase condition when the DER is at 5% output.
- Loss of phase via undervoltage relaying detection is inadequate for identifying an open phase condition. Ground banks and delta winding, present on both the DER site and on the larger Area EPS, may reconstruct voltage at the open point of the RPA.

#### **6.3.6. Single-phase on Multiphase Services<sup>11</sup>**

The total nameplate rating for an individual single-phase inverter on a multi-phase system cannot exceed 10% of the distribution transformer rating that is supplying the service.

Multiple single-phase DER systems which are connecting to a multi-phase service to form a three-phase generation source, must provide protection to allow sensing and tripping of the entire DER system upon loss of a single individual phase.

DER systems which are connecting to an existing two-phase Open Delta-Wye or Open Wye-Delta secondary must be single-phase or the voltage of the service shall be converted to 120/208 or 277/480 volts.

### **6.4 Interconnection Transformers Connections**

Interconnection Customer-owned transformers that are part of the DER system shall fall under one of the following connections.

#### **6.4.1 Wye-Wye Transformer Connections**

A Wye-Wye transformer is the preferred transformer connection. Both the primary and secondary of the transformer must be grounded. Do note, this transformer connection is subjected to harmonics from the Area EPS and the

DER must be designed to limit the harmonic output from the DER system to below IEEE standard levels.

#### **6.4.2 Wye-Delta Transformer Connections**

The wye side of the transformation is required to be grounded.

High side voltage monitoring to sense single-phase faults on the primary side of the transformer is required.

All issues with zero sequence injections into the Area EPS from the Grounded Wye winding shall be addressed. Documentation is required to be provided to the Area EPS Operator for review.

#### **6.4.3 Delta-Wye Transformer Connections**

This transformer configuration is not allowed for interconnection of a DER system.

### **6.5 Grounding**

For Interconnection Customer provide transformers that are part of the DER system, the transformer grounding shall properly interconnect with the grounding of the Area EPS.

#### **6.5.1 Requirement of Grounding Transformer**

Grounding transformers are not required by the Area EPS Operator.

#### **6.5.2 Wye-Wye Interconnection**

For Wye-Wye transformer configurations both the primary and secondary side of the transformer shall be grounded. The DER must also include an appropriately sized ground bank or the generator's neutral must be adequately grounded.

#### **6.5.3 Wye-Delta Interconnection**

For Wye-Delta transformer configurations the wye side is required to be grounded.

#### **6.5.4 Delta-Wye Interconnection**

Delta-Wye transformer configurations are not allowed by the Area EPS Operator for DER system interconnected to the Area EPS.

## **7. Operations**

### **7.1 Periodical Testing & Record Keeping**

*The Interconnection Customer shall notify the Area EPS Operator prior to any of the following events occurring:*



- *Protection functions are being adjusted after the initial commissioning process.*
- *Functional software or firmware changes are being made on the DER.*
- *Any hardware component of the DER is being modified in the field or is being replaced or repaired with parts that are not substitutive components compliant with this standard.*
- *Protection settings are being changed after factory testing.*

*Prior to modifications to the DER triggering reverification, the Interconnection Customer shall notify the Area EPS Operator's interconnection coordinator, by emailing bcrea@bcrea.coop. The email should include details about the proposed modification and the DER contact to communicate with for additional information, if needed. The Area EPS Operator strongly encourages using the DER Alteration Notification form shown in Appendix F to provide the necessary information. Any of the above events may be cause for requiring reverification of the interconnection and interoperability requirements as stated in the MN DER TIIR Section 14.5.*

All interconnection-related protection and control systems shall be periodically tested and maintained, by the Interconnection Customer, at intervals specified by the manufacturer or system integrator and shall not exceed five years. Periodic test reports and a log of inspections shall be maintained by the Interconnection Customer and made available to the Area EPS Operator upon request. The Area EPS Operator shall be notified prior to the testing of the protective and control systems to witness the testing if so desired. The testing procedure for re-test should be a functional test of the protection and control systems.

The Area EPS Operator requires any system that depends upon a battery for trip/protection power shall be checked and logged once per month for proper voltage. For DER systems with nameplate rating of 1,000 kW or more, continuous monitoring of the DC battery voltage is required. Logging of all periodic inspection is recommended.

## **7.2 O&M Agreements**

For DER systems that operate in parallel with a capacity of 40 kW or greater, the Operating and Maintenance Requirements<sup>1</sup> section of the Interconnection Agreement is established. The Operating and Maintenance Requirements section of the Interconnection Agreement covers items that are necessary for the reliable operation of the Local and Area EPS and are unique to each DER. The items included as Operating Requirements shall not be limited to the items shown on this list:

---

<sup>1</sup> Attachment V of the Interconnection Agreement is the Operating and Maintenance Requirements for Area EPS Operator's Distribution System and Affected Systems Need to Support the Interconnection Customer's Need. This is referred to as the Operating and Maintenance Requirements in this document.

- i. *Operational requirements, settings, and limits for DER when the Area EPS is in a normal condition*
- ii. *Operational requirements, settings, and limits when the Area EPS is in an abnormal condition due to maintenance, contingencies, or other system issues*
- iii. *Permitted and disallowed ESS Control Modes*
- iv. *BPS or TPS limitations and arrangements that could impact DER operation*
- v. *DER restoration of output or return to service settings and limitations*
- vi. *Response to control or communication failures*
- vii. *Performance category assignments (normal and abnormal)*
- viii. *Dispatch characteristics of DER*
- ix. *Notification process between Interconnection Customer and Area EPS Operator*
- x. *Right of Access*

*The following is a list of typical items that may be included as Maintenance Requirements. The items included as Maintenance Requirements shall not be limited to the items included in this list:*

- i. *Routine maintenance requirements and definition of responsibilities*
- ii. *Material modification of the DER that may impact the Area EPS*

### **7.3 System Voltage**

Operation of the DER shall not cause the voltage at the PCC to go outside of ANSI Range A under normal operations. Operation of the DER that causes voltages to go outside the ANSI Range A voltage values may be cause for disconnection until the reason can be identified and corrected.

Any sudden voltage changes caused by the DER which adverse effect other interconnected entities to the Area EPS shall not be allowed. It is the DERs responsibility to resolve adverse voltage changes caused by the operation of their DER. The Area EPS Operator will work cooperatively with the DER to identify possible solutions.

### **7.4 Power Ramp Rates**

#### **7.4.1 Overview**

The ability for the Area EPS to response to large changes in increasing or decreasing demand for energy depend upon the PCC with the Area EPS. The ratio of generation to load on the Area EPS correlates with the potential of voltage disturbances on the Area EPS as generation is abruptly added or removed from extended parallel operation with the Area EPS. In some cases, if the step change is large enough, Area EPS protection devices may operate under the assumption a fault has occurred with the abrupt change in voltage. The larger the amount of load or generation added or removed from the Area

EPS, the greater the chance of creating operational problems for other entities interconnected on the Area EPS.

As part of the interconnection study, the Area EPS Operator will review the potential for step changes of 3% or greater in load or energy production that can create operational problems on the Area EPS. It is the Interconnection Customer’s responsibility to review for potential Local EPS issue which may result from block changes in load or generation from the DER.

**7.4.2 Power Ramp Rates Requirements**

DER systems shall not cause the Area EPS voltage to be outside of ANSI Range A voltage levels. Block loading or off-loading of the DER generation that causes voltage step changes of 3% or greater on the Area EPS is not allowed.

**7.5 Enter Service**

Enter Service is the period where the DER begins operation with an energized Area EPS. Enter Service may be part of daily operation of the DER or occur after a power outage on the Area EPS. The method the DER uses to Enter Service is important to the reliability and performance of the Local EPS and the Area EPS. All DER systems shall not energize and parallel with the Area EPS unless applicable voltage and system frequency are within the ranges specified in Table 5.

*Table 5 – DER Enter Service Criteria Ranges*

Enter Service Criteria		Default settings
Applicable voltage within range	Minimum Value	≥ 0.917 p.u.
	Maximum Value	≤ 1.05 p.u.
Frequency within range	Minimum Value	≥ 59.3 Hz
	Maximum value	≤ 60.5 Hz

*DER shall be capable of delaying enter service by an intentional adjustable minimum delay when the Area EPS steady-state voltage and frequency are within the ranges specified in Table 5. The adjustable range of the minimum intentional delay shall be 0 s to 300 s with a default minimum delay of 300 s.*

**7.5.1 DER without ESS**

For DER that does not include ESS, possible methods which may be required include:

- The delay time for re-energization of the DER after an outage may be increased.
- The DER may be required to stagger the re-energization of inverters.
- Multiple transfer switches may be required to divide up the blocks of load transferred to the DER.

### 7.5.2 Energy Storage Systems

ESS shall be set to an intentional delay of a minimum of 300 s, (5 minutes), before initiating recharging of the ESS. If possible, the Area EPS Operator would prefer the ESS ramp up the recharging level from 0 – 100% over the first ten-minute time period of initial recharging. ESS larger than 250 kW may be required to have a specific intentional delay prior to enter service. The specific delay will be documented in the Operating and Maintenance Requirements section of the Interconnection Agreement.

## 8. Power Control Systems

### 8.1 General

**Power Control:** *System that controls the output (production or discharging) and input (charging) of one or more DER in order to limit output, input, export and/or import.*

Power control systems are used to control the output from a DER system due to an external condition. For example, the output from a DER unit may be limited so that it does not export energy back into the Area EPS system at the PCC. To accomplish this the power control system would sense the flow of energy at the PCC and relay that information back to the DER to limit DER output if there was any reverse energy flow at the PCC.

### 8.2 Power Control System Requirements

The power control system must be NRTL certified control system that meets the following requirements.

- Able to halt or reduce energy production within two seconds after either the period of continuous export to the Area EPS exceeds 30 seconds or the level of export exceeds the lesser of 100 kW or 10% of the DER nameplate rating.
- Able to monitor the total energy exported.
- Able to self-monitor the Power Control System, such that failure of the ability to monitor the energy flow or failure of the ability to control the output of the DER, results in halting the production of energy by the DER or the separation of the DER system from parallel operation with the Area EPS.
- The configuration and settings governing the power control limiting functions shall be password protected, accessible only by qualified personnel.
- The power to the control system must be battery backed up and if the power to the control is not available the DER system must be blocked from operation.

### 8.3 Documentation

DER applications that include a power control system must also include additional information specific to the power control system. At minimum, the following information should be supplied to the Area EPS Operator regarding the power control system.

- Make and model of the power control system.
- Electrical schematic of the monitoring for the power control system.
- User manual for the control of the power control system.
- Response time to modifying the output of the DER, in response to a large step change in the local electrical loads.
- Description of the operating reason and modes (shown in the user manual) which will be utilized.
- Description of how other operating modes (shown in the user manual) are being restricted so they are not able to be enabled.
- Other information which is useful to help the Area EPS Operator understand the power control system.

Prior to final interconnection, the Interconnection Customer shall supply updated power control system documentation to the Area EPS Operator.

#### **8.4 Inadvertent Export**

Inadvertent export is the flow of energy, in excess of a defined amount, through the PCC and back onto the Area EPS. Inadvertent export can have a detrimental effect on the Area EPS, damaging equipment or causing a power outage.

Inadvertent export shall be limited to 10% of the nameplate DER rating or 100 kW, whichever is less, for a maximum of 30 seconds. The cumulative amount of inadvertent exported energy from the Local EPS to the Area EPS, across the PCC, in any billing month shall be less than the on-site aggregated DER Nameplate Rating(s) multiplied by one hour. The power control system shall be designed to limit inadvertent export to these levels, unless mutually agreed to between the Interconnection Customer and Area EPS Operator and documented in the Operating and Maintenance Requirements section of the Interconnection Agreement.

Any amount of inadvertent export of real power across the PCC lasting longer than 30 seconds for any single event shall result in the disconnection of the DER system from the Area EPS within two seconds of exceeding the 30 second duration limit.

## **9. Interoperability**

### **9.1 Overview**

Depending on the method of interconnection and the size of the DER system, there are different interoperability requirements. Information from the DER is needed for the Area EPS Operator to perform fault analysis, load flow and system reliability analysis. Remote monitoring and remote control maybe required depending on the size of the DER, type of interconnection and the mode of operation. In general, Table 6 displays the need for remote monitoring and remote control of the DER by size. DER with ESS that do not export may have different monitoring and control requirements.

Specific remote monitoring and control requirements will be identified in the Operating and Maintenance Requirements of the Interconnection Agreement.

*Table 6 – Monitoring and Control Requirements for DER Systems*

<b>Monitoring and Control Requirements for DER Systems</b>		
<b>DER System Nameplate Capacity</b>	<b>DER Remote Monitoring</b>	<b>DER Remote Control</b>
0 – 60 kW	None Required	None Required
60 – 1,000 kW	SCADA Monitoring Likely	Remote control via Area EPS Operator’s SCADA Possible
> 1,000 kW	SCADA Monitoring Required	Remote control via Area EPS Operator’s SCADA Likely

**9.2 Sales to Parties Other Than the Area EPS Operator**

The TSM does not address the metering, monitoring and control requirements for DER system whose energy sales are to a party other than the Area EPS Operator. For energy sales to a party other than the Area EPS Operator, the monitoring and control requirement will be identified in the Operating and Maintenance Requirements section of the Interconnection Agreement.

**9.3 Level of Communication Required**

When SCADA monitor or SCADA monitoring and control is required, the DER Owner is responsible for the cost to provide the communications to the Area EPS Operator’s control center. For DER system larger than 1,000 kW requiring monitoring and control, the Area EPS Operator will install the communication channel. The Interconnection Customer is responsible for the Area EPS Operator’s cost of the communication channel.

The communication channel shall meet the following requirements:

- Available via a VPN tunnel,
- Able to support a polling rate of once every 10 seconds,
- Encrypted,
- Utilize DNP3.0 protocol, and
- Include a battery backup system that can last for a minimum of 8 hours during an Area EPS outage.

**9.4 Level of Monitoring and Control Required**

The actual list of status, control and analog points required to be monitored and controlled by the Area EPS Operator are to be defined in the Operating and

Maintenance Requirements section of the Interconnection Agreement. In general, the minimum points that will be required for DER systems 1,000 kW and greater are:

- **Status Points**
  - Lockout relay status
  - High voltage alarm
  - Low voltage alarm
  - Relay failure alarm (for each protective relay)
  - Interconnection breaker(s) status (open/close)
  - DC battery charger alarm
  - General trouble alarm
- **Control Points**
  - Remote control of interconnection breaker(s)
  - Ability to curtail the output of the DER to a specific level
  - Ability to remotely change and/or monitor modes of operations that are active
- **Analog Values**
  - Phase voltage (phase to ground)
  - DER phase current (amp) output
  - Frequency
  - Power Factor (including leading/lagging)
  - DC voltage of backup battery system
  - Current Total Harmonic Distortion
  - Voltage Total Harmonic Distortion
  - Three-phase real (kW) and reactive (kVA) power flow of each DER unit

## **9.5 Security**

In general, all physical, network and local DER communication interface security protections should be identified by the Interconnection Customer and approved by the Area EPS Operator. Specific security requirements are listed in Sections 9.5.1, 9.5.2 and 9.5.3.

### **9.5.1 Physical and Front Panel**

The Interconnection Customer shall maintain physical security for the DER equipment and all communication interfaces at the DER site. All configuration settings for the DER system shall be password protected to allow access only to qualified personnel. Other physical security protections shall be identified by the Interconnection Customer and approved by the Area EPS Operator.

### **9.5.2 Network Security**

Dependent on the DER interconnection, additional network security may apply. If needed, the additional requirements will be identified in the Operating and Maintenance Requirements section of the Interconnection Agreement.

### **9.5.3 Local DER Communication Interface Security**

Dependent on the DER interconnection, additional local DER communication interface security may apply. If needed, the additional requirements will be identified in the Operating and Maintenance Requirements section of the Interconnection Agreement.

## **10. Energy Storage Systems**

### **10.1 Grid Support Functions**

The TSM will not address technical issues that may arise with grid support functions. Grid support functions, such as frequency and voltage support, are currently not address by the Area EPS Operator's rate tariff. Until MISO rules and required associated Minnesota PUC dockets have been determined, the use of an ESS to provide grid support functions is not allowed.

### **10.2 Common Modes of Operation**

Energy storage systems are still an evolving technology with different use cases and modes of operation. Multiple control modes may be utilized by the Interconnection Customer. When applying for interconnection with the Area EPS, the DER Applicant should indicate what control modes of operation are being utilized. The Interconnection Customer must not change the control mode of the ESS without notification to the Area EPS Operator. The Area EPS Operator only studies the ESS under the indicated operation mode(s) listed on the original interconnection application. Common modes of operations used in ESS are explained in Appendix C.

### **10.3 Enter Service**

After any sustained electrical outage, the ESS shall be configured to not immediately initiate recharging of the ESS. Per the IEEE 1547 standards the ESS shall wait a minimum of 5 minutes after the Area EPS is reenergized and provides a stable voltage, before initiating recharging of the ESS.

It is preferable to delay any recharging of the ESS for a minimum of 10 minutes after reenergization of the Area EPS, to allow the distribution system to fully stabilize and reduce the possibility of additional electrical demand caused by the recharging of the ESS to overload the distribution system.

To help reduce the possibility of step voltage issues and other distribution system issues, it is preferable to have the ESS control system ramp up the recharging level from 0-100% over a 5-minute time period upon entering service.

### **10.4 Modification of Control Modes**

*ESS Control Modes may not necessarily be considered a Material Modification, however the Interconnection Customer shall notify the Area EPS Operator of an unapproved ESS Control Mode prior to the change being implemented. The Area EPS*



*Operator shall discuss with the Interconnection Customer the need, or lack thereof, to review the proposed ESS Control Mode for safety, power quality or reliability reasons.*

The Interconnection Customer can inform the Area EPS Operator of a change in ESS control mode by emailing the Area EPS Operator's DER Coordinator a DER Alteration Notification indicating the change in control mode. The DER Alteration Notification is shown in Appendix F. The DER Coordinator can be reached at [bcrea@bcrea.coop](mailto:bcrea@bcrea.coop). The ESS should not be operated in the new control mode without approval from the Area EPS Operator.

## **11. Metering Requirements<sup>1</sup>**

The metering requirement for each DER system will depend on the DER size, location, interconnection type and application rate schedules. It is the Interconnection Customer's responsibility to provide metering sockets as applicable. The Area EPS Operator will provide the meter(s), CTs and VTs, unless the DER sales are to a third party. For DER with sales to a third party, the Interconnection Customer shall be responsible for all metering costs incurred by the Area EPS Operator.

### **11.1 DER Interconnection on Services with Subtractive Metering**

The Area EPS Operator does not allow for DER systems of the extended parallel type to be on an electric service where subtractive metering already exists. Consult with the Area EPS Operator of alternative options.

### **11.2 Metering Required for DER Installation**

The metering required for DER system depends on the size and type of DER, the method of interconnection and applicable rate programs the DER may take part in. There may be unique installations which may require deviations from requirements listed in this document. Deviations from this specification will be documented in the Operating and Maintenance Requirements section of the Interconnection Agreement.

#### **11.2.1 Main Service Meter**

The main service meter, is located at the PCC, unless mutually agreed upon between the Area EPS Operator and Interconnection Customer<sup>2</sup>, and is the meter the Area EPS Operator shall use for billings purposes. This is commonly called a bidirectional meter.

#### **11.2.2 Production Meter**

A production meter may be required by the Area EPS Operator and is located electrically at the PoC. This meter will monitor the power flow to and from the DER. The production meter may be used for incentive programs or standby calculations and provides the Area EPS Operator with necessary information to properly engineer a

---

<sup>2</sup> If the main meter is not be located at the PCC, the Interconnection Agreement shall document the agreed upon losses and billing will be adjusted accordingly.

safe and reliable grid. The Area EPS Operator does require a production meter for specific DER installation as listed in Section 11.3.

### **11.3 Production Meter Requirement**

#### **11.3.1 DER Systems with ESS**

There are multiple variations of DER systems that include ESS. Depending on the configuration, non-exporting DER systems that incorporate ESS may not need a production meter. Consult with the Area EPS Operator to determine the proper metering needs.

#### **11.3.2 Extended Parallel DER Interconnections**

The Area EPS Operator requires the main meter at the PCC and a production meter at the PoC. The Area EPS Operator will reprogram or replace the main service meter to be able to measure and record power flow in both directions. It is the responsibility of the Interconnection Customer to install and provide the appropriate meter socket or setup at the PoC. The Area EPS Operator will provide the meter to record production. For DER systems where the PCC and PoC are the same location a single meter can perform both types of metering.

#### **11.3.3 All Other DER Interconnections**

DER interconnections that are not extended parallel will need to refer to the Area EPS Operator for the appropriate metering needs.

### **11.4 Acceptable Metering**

A brief list of metering specifications is listed in the following subsections. Variation from the Area EPS Operator requirements will need to be mutually agreed to by the Area EPS Operator and documented in the Operating and Maintenance Requirements section of the Interconnection Agreement.

#### **11.4.1 Meter Sockets**

The interconnection owner is responsible for purchasing and installing a meter socket that meets the following requirements and is appropriate for the service connect.

- Meter sockets must be UL (Underwriters Laboratories) or ARL (Applied Research Laboratories) approved.
- All metering for a single service must be grouped in a 10-foot area.
- All self-contained meter sockets must be a bypass type socket with a manually operated lever bypass with a minimum amperage size of 200 amps.

#### **11.4.2 Location and Accessibility**

The meter socket shall be installed in a location that meets the following specifications:

- The center of the meter socket shall be located at a height between 4 to 6 feet above the ground.
- Location and path to the meter socket must be continuously clear and free of hazards for anyone accessing the meter.
- Meter sockets must be a minimum of 3 feet away from a gas meter and 6 feet away from combustible storage.
- Meter sockets shall have unobstructed space of at least 3 feet in front and 1 foot to each side.
- Meter socket shall be installed within 10 feet of the service transformer.

The specifications for meter socket location and accessibility shall be maintained for the life of the meter use. If changes cause the meter to no longer meet the stated specifications, the meter shall be moved to a new accessible location at the expense of the Interconnection Customer.

#### **11.5 Type of Metering Configurations**

Please see Appendix D for expected metering configurations.

## **12. Signage and Labeling<sup>1</sup>**

### **12.1 General Requirements**

All signage and labeling shall meet applicable NEC requirements including NEC 110.21 (B), 690.13 and 750.10.

### **12.2 Utility AC Disconnect**

The Utility AC disconnect shall be labeled as "UTILITY AC DISCONNECT". The Utility AC Disconnect shall be located within 10 feet of the main service meter. The Area EPS Operator and the Interconnection Customer may mutually agree to install the Utility AC Disconnect at a location greater than 10 feet from the main service meter.

#### **12.2.1 Multiple AC Disconnects**

If a single Utility AC Disconnect cannot be used to disconnect all DERs, all Utility AC disconnects should include numerical identification such as "UTILITY DER AC DISCONNECT 1 OF 2" or similar. The number of disconnects required to be operated to isolate the DER from the utility should be clear.

### **12.3 Production Meter**

The production meter shall be labeled as "DER PRODUCTION METER" or similar. If there are multiple DER types present at a location the production meter shall indicate the type of DER behind the meter.

## **13. Test and Verification Requirement<sup>1</sup>**

### **13.1 Applicability**

Testing and verifications of the Interconnection Customer's DER system to validate compliance with the interconnection agreement, TIIR and Area EPS Operator's TSM is critical to maintaining the safe and reliable system. The testing and verifications requirements that follow will apply to the RPA and PCC unless mutually agreed upon between the Area EPS Operator and the Interconnection Customer.

### **13.2 Certified DER Systems**

It is understood that DER systems that are certified by UL 1741 / IEEE 1547 have already undergone scrutiny and testing. As such the testing required to commissioning these systems is designed to recognize the previous testing and focus on integration with the Area EPS and the final installed DER. The following testing requirements shall be met prior to parallel operation with the Area EPS:

- 1) Verifications of certified equipment make and model.
- 2) Verification of system wiring.
- 3) For new installations, verification of meter with Area EPS Operators AMI system.
- 4) Verification of anti-islanding.
- 5) Verification of grounding.

### **13.3 Non-Certified DER Systems**

For non-certified systems it is the Interconnection Customer's responsibility to provide a final design for approval and to install the protective measures required by the Area EPS Operator. Mutually agreed upon exception may at times be necessary and desirable. Prior to Commissioning of the DER the Interconnection customer shall provide the design with proof that it shall not connect or close into a de-energized Area EPS. The Interconnection Customer shall obtain written approval of the design as installed prior to completing the commissioning testing of the DER.

### **13.4 Pre-Energization Testing – Interconnection Customer**

The following testing shall be performed by the Interconnection Customer. The Area EPS Operator has the right to witness all field test and review all records prior to

allowing the system to be made ready for normal operation. The Area EPS Operator shall be notified with adequate lead time of witness testing in accordance to C-MIP<sup>3</sup>.

- 1) Grounding shall be verified to ensure that it complies with this specification, the NESC and the NEC.
- 2) CT's (Current Transformers) and VT's (Voltage Transformers) used for monitoring and protection, shall be tested to ensure correct polarity, ratio and wiring.
- 3) CT's shall be visually inspected to ensure that all grounding and shorting connections have been removed where required.
- 4) Breaker / Switch tests – Verify that the breaker or switch cannot be operated with interlocks in place or that the breaker or switch cannot be automatically operated when in manual mode. (The intent of this test is to ensure that the breaker or switch controls are operating properly).
- 5) Relay Tests – All protective relays shall be calibrated and tested to ensure the correct operation of the protective element. Documentation of all relay calibration tests and settings shall be furnished to the Area EPS Operator.
- 6) Trip checks – Protective relays shall be functionally tested to ensure the correct operation of the complete system. Functional testing requires that the complete system is operated by the injection of currents and/or voltage to trigger the relay elements and prove that the relay element trips the required breaker, lockout or provides the correct signal to the next control element. Trip circuit shall be proven through the entire scheme (including breaker trip).
- 7) Remote Control, SCADA and Remote Monitoring tests – All remote-control functions and remote monitoring points shall be verified operational. For some monitoring points it may not be possible to verify analog values prior to energization. Where appropriate, those points may be verified during the energization process.
- 8) Phase Tests – the Interconnection Customer shall work with the Area EPS Operator to complete the phase test to ensure proper phase rotation of the DER system and wiring.
- 9) Synchronizing test – The following tests shall be done across an open switch or racked out breaker. The switch or breaker shall be in a position that it is incapable of closing between the Generation System and the Area EPS for this

---

<sup>3</sup> C-MIP Simplified Process section 8.3, Fast Track Process section 9.4 and Study Process section 11.3

test. This test shall demonstrate that at the moment of the paralleling-device closure, the frequency, voltage and phase angle are within the required ranges, stated in IEEE 1547. This test shall also demonstrate that if any of the parameters are outside of the ranges stated; the paralleling device shall not close. For inverter-based interconnected systems this test may not be required unless the inverter creates fundamental voltages before the paralleling device is closed.

### **13.5 Energization Testing Criteria**

Some tests are unable to be performed prior to interconnection with the Area EPS. Once the pre-energization tests are completed, the DER shall be integrated and the energization tests shall be performed. For larger and more complex DER systems the Interconnection Customer and Area EPS Operator should work together to develop the required testing procedure. Final proposed testing procedure shall be submitted to the Area EPS Operator prior to energization testing. The testing procedure should include the location, method of operation and verification for each step. At minimum, the testing procedure shall include the steps listed in Section 13.5.1 and 13.5.2.

#### **13.5.1 Installation Verification**

Prior to the anti-islanding testing, the DER system shall have the following verified:

- 1) That there is continuous, unescorted site access to the Area EPS equipment and Utility DER AC Disconnect is available. Site access means drivable and keyless access.
- 2) The DER installation matches the submitted one-line diagram that was approved by the Area EPS Operator.
- 3) There is proper labeling of disconnect switches, meters and placards, if necessary.
- 4) That the Interconnection Customer will verify the settings and firmware of the inverters, protective devices, power control systems and other hardware and software components comply with the TIIR, Area EPS Operator's TSM, operating agreements and match the previously approved settings.

#### **13.5.2 Anti-Islanding Test**

For DER systems that operate in parallel with the Area EPS, the anti-islanding test procedure shall, at minimum, contain the following steps:

- 1) The DER system shall be placed into normal operations.
- 2) The DER system shall be verified it is energized and generating.

- 3) The Area EPS source shall be removed from the DER system. For multi-phase systems, the Area EPS source shall be removed by one individual phase at a time.
- 4) The DER system shall be verified that it either separate from the Area EPS together with the local load or the DER system shall stop operating.
- 5) The DER system shall be reconnected to the Area EPS. The DER generation shall not parallel with the Area EPS for a period less than 5 minutes.

For each step, the testing procedure shall identify which device shall be operated to complete the step. In verification step, the testing procedure shall identify the point of measurement.

### **13.5.3 Additional Onsite Testing**

Depending on the complexity of the DER system, additional energization tests may be required. Examples of additional tests include phase testing, control mode verification, SCADA and communication verification. These additional tests shall be listed in the Interconnection Customer's submitted testing procedure as applicable.

## **13.6 Periodic Testing and Documentation**

All interconnection-related protection systems shall be periodically tested and maintained, by the Interconnection Customer, at intervals specified by the manufacturer or system integrator. These intervals shall not exceed five years. Periodic test reports and a log of inspections shall be maintained, by the Interconnection Customer and made available to the Area EPS Operator upon request. The Area EPS Operator shall be notified prior to the period testing of the protective systems, so that Area EPS personnel may witness the testing, if so desired.

### **13.6.1 Battery Documentation**

Any system that depends upon a battery for trip/protection power shall be checked and logged once per month for proper voltage. Once every four years the battery(s) must be either replaced or a discharge test performed. Longer intervals are possible using the "station class batteries" and Area EPS Operator approval.

## **13.7 Failure Protocol**

If the DER fails testing and verification, the Interconnection Customer shall address outstanding issues and provide updated documentation to the Area EPS Operator regarding the changes made. The Interconnection Customer shall re-schedule the onsite testing with the Area EPS Operator and provide a revised testing procedure, if necessary.

### **13.8 Modification to Existing DER**

Any time the interface hardware or software, including protective relaying and generation control systems are replaced and/or modified, the Area EPS Operator shall be notified. This notification shall, if possible, be with adequate so the Area EPS personnel can be involved in the planning for the modification and/or witness the verification testing. Verification testing shall be completed on the replaced and/or modified equipment and systems. The involvement of the Area EPS personnel will depend upon the complexity of the DER system and the component being replaced and/or modified.

## **14. Sample Documents for Simplified Process**

### **14.1 Introduction**

Interconnection customer shall maintain a system one-line diagram, site diagram and testing procedure with latest results.

All documentation shall include the following:

- Interconnection Customer's Name
- Interconnection Agent's Name, Address, and Phone Number
- Date and revision

### **14.2 One-Line Diagram**

The one-line diagram shall include, but not limited to, the following information:

- Applicant Name
- Application ID
- Installer name and contact information
- Address where DER system will be installed
- Correct electrical position of all equipment, including but not limited to: Panels, Inverter, DC and AC disconnects.
- Distance between equipment
- Labeling found on equipment
- Total Aggregated AC nameplate rating of DER
- DER protection elements

The one-line diagram shall be signed and stamped by a Minnesota Professional Engineer if the DER is larger than 20 kW and uncertified or larger than 250 kW and certified.



Figure 14.1 – Example Simplified One-Line Diagram

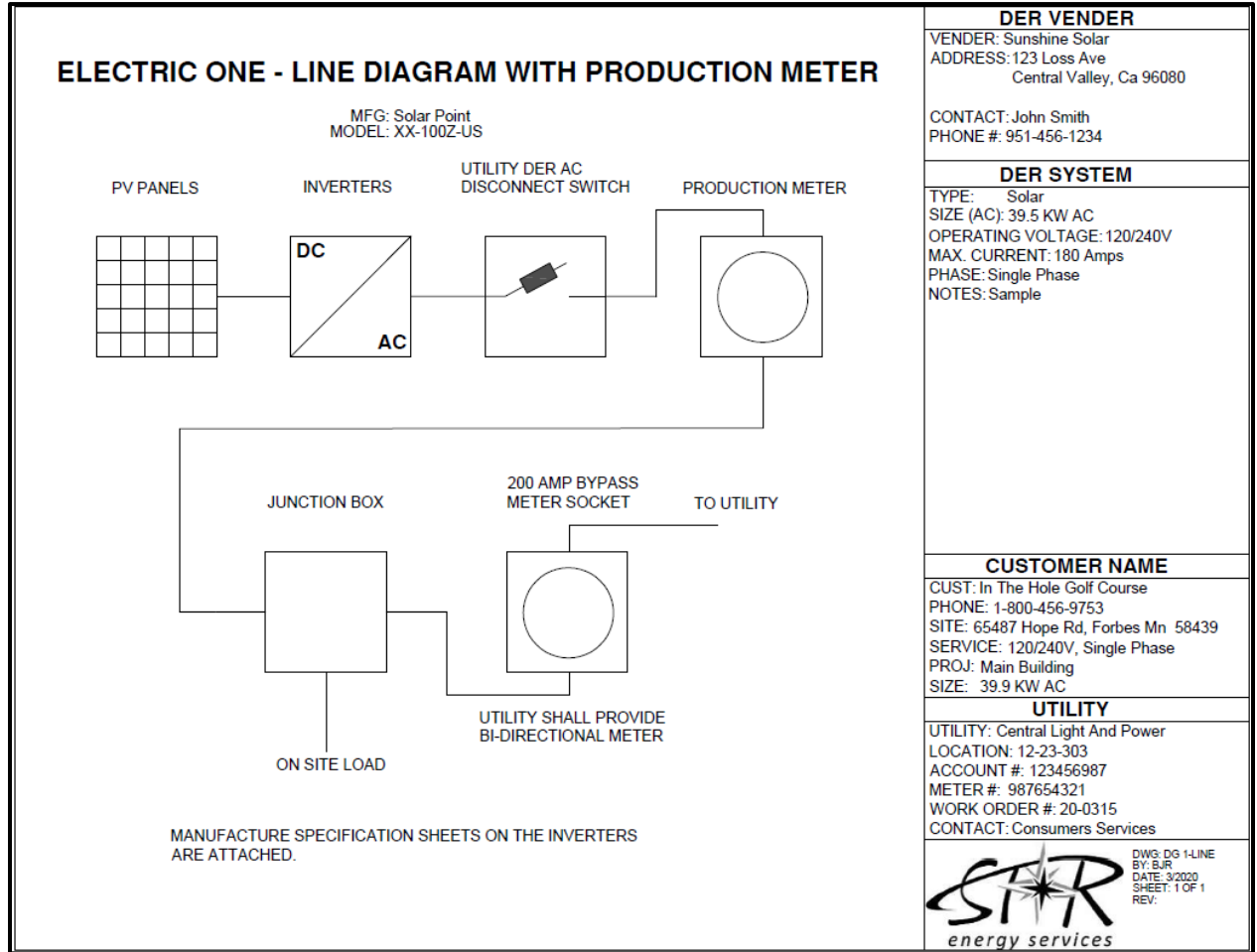

### 14.3 Site Diagram

Site Diagram shall include the following:

- Shall be to scale
- Location of DER
- Location of meter(s)
- Location of Utility AC disconnect
- Location of PCC/RPA/PoC
- Location of underground/overhead electrical wires
  - If underground, shall include any easements/right of ways

Figure 14.2 – Sample Simplified Site Diagram

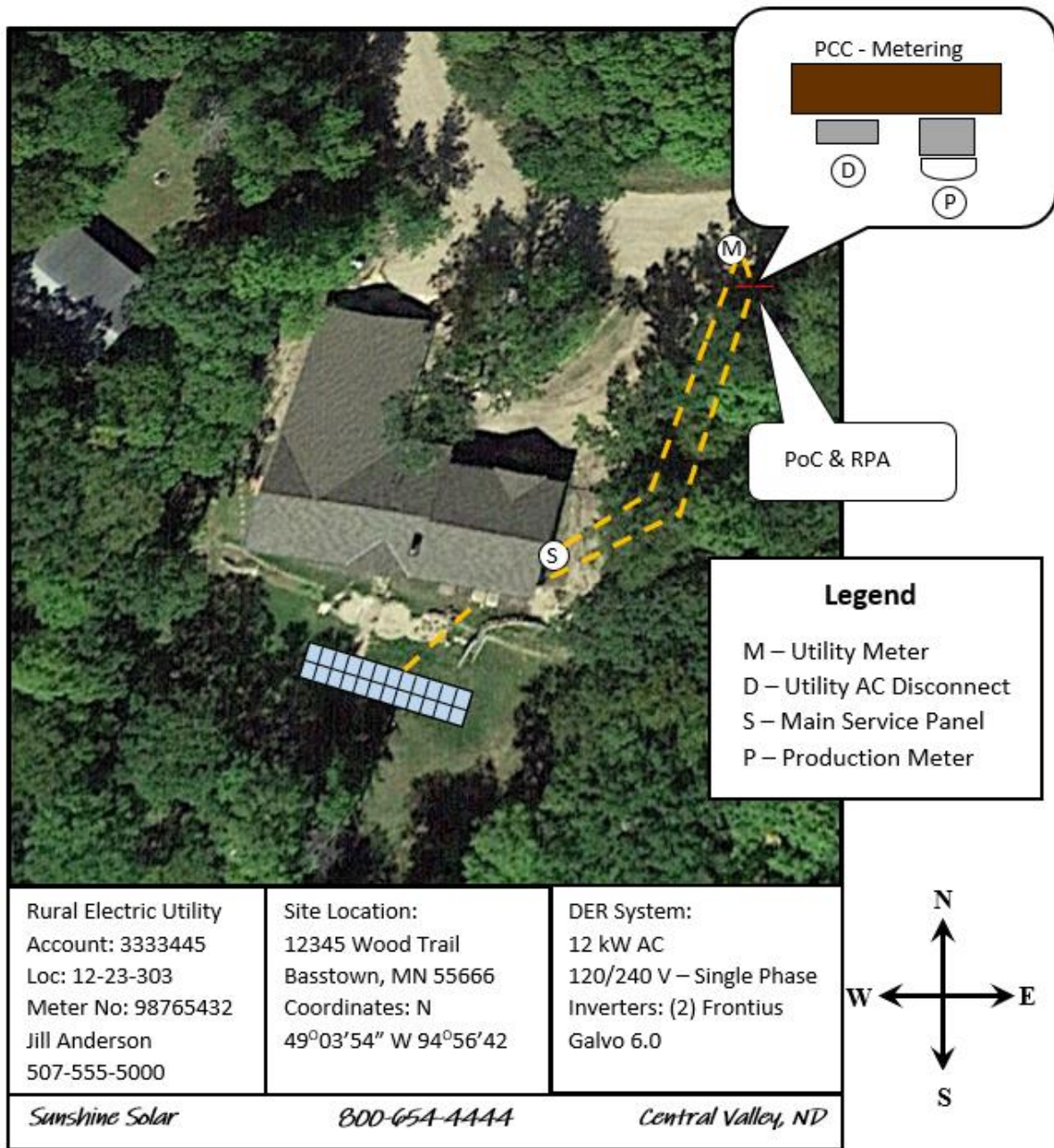

## 14.4 Testing Procedure

### General Process for Simplified Testing Procedures

- Verify installation matches design evaluation
  - Verify inverter model matches application
  - Verify certified inverter
  - Verify electrical inspection sticker
  - Verify correct labeling / signage
  - Verify Utility DER AC Disconnect Switch is lockable and has visual open
  - Verify DER system installation matches application one-line
  - Verification of operational and protection settings
  - Verify metering and Utility DER AC Disconnect Switch are accessible by Area EPS Operator
  
- Field Testing
  - On-off test
  - Open phase testing (if applicable for multiphase systems)

An example of a Simplified DER testing procedure is found in Appendix E.

## Appendix A – Types of Interconnection

The way the DER system is connected to and disconnected from the Area EPS can vary. Most transfer systems normally operate using one of the following five methods of transferring the load from the Area EPS to the DER system.

If a transfer system is installed which has a user accessible selection of several transfer modes, the transfer mode that has the greatest protection requirements will establish the protection requirements for that transfer system.

### **Open Transition (Break-Before-Make) Transfer Switch**

With this transfer switch, the load to be supplied from the DER is first disconnected from the Area EPS and then connected to the DER. This transfer can be relatively quick, but voltage and frequency excursions are to be expected during transfer. Computer equipment and other sensitive equipment will shut down and reset. The transfer switch typically consists of a standard UL approved transfer switch with mechanical interlocks between the two source contactors that drop the Area EPS source before the DER is connected to supply the load.

- 1) To qualify as an Open Transition switch and the limited protective requirements, mechanical interlocks are required between the two source contacts. This is required to ensure that one of the contacts is always open and the generating DER is never operated in parallel with the Area EPS. If the mechanical interlock is not present, the protection requirements are as if the switch is a closed transition switch.
- 2) As a practical point of application, this type of transfer switch is typically used for loads less than 500 kW. This is due to possible voltage flicker problems created on the Area EPS, when the load is removed from or returned to the Area EPS source. Depending upon the Area EPS's stiffness, this level may be larger or smaller than the 500-kW level.
- 3) Figure 1 on the following page provides a typical one-line of this type of installation.

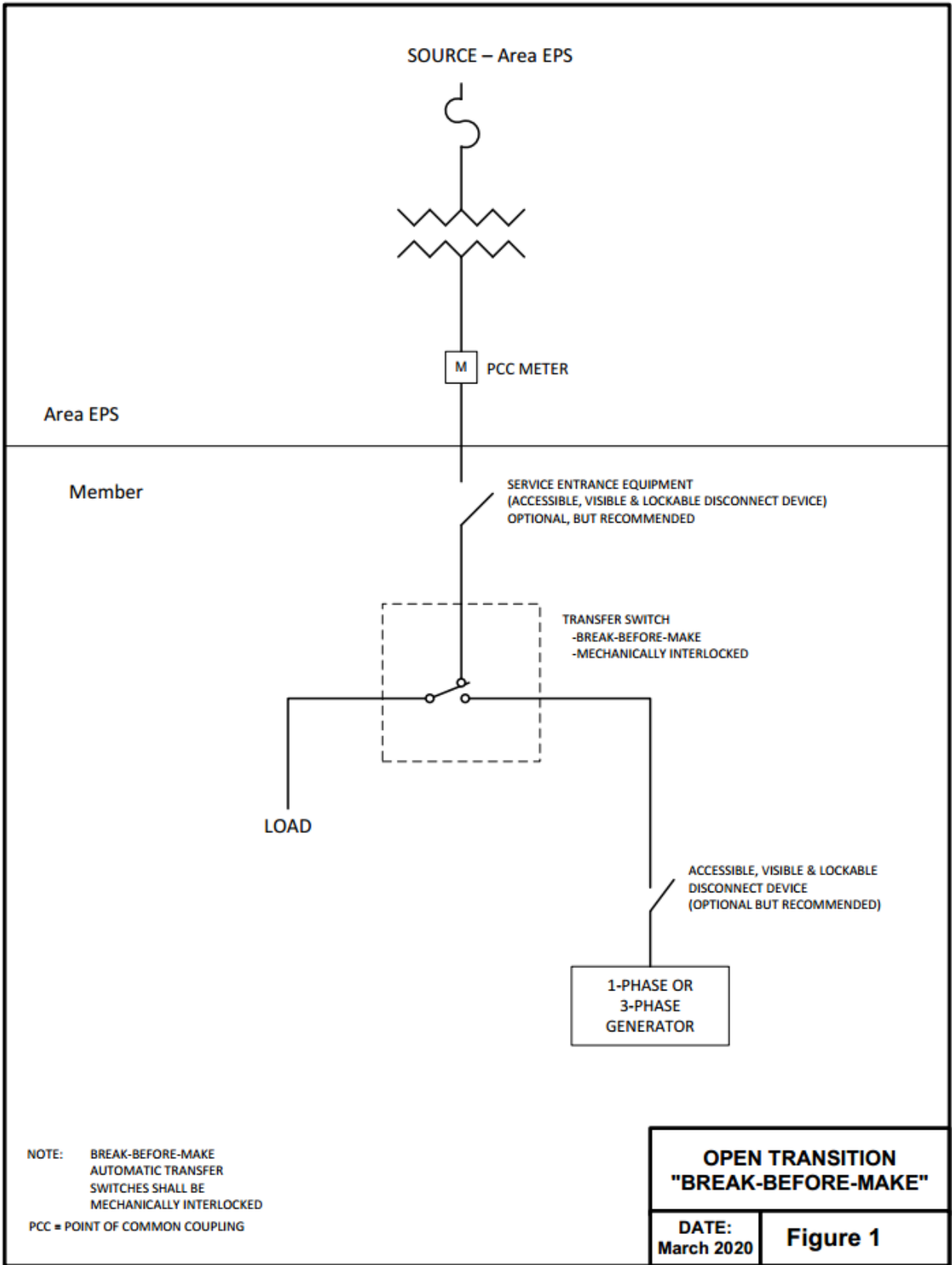

### **Quick Open Transition (Break-Before-Make) Transfer Switch**

For a Quick Open Transition, the load to be supplied from the DER is first disconnected from the Area EPS and then connected to the DER, similar to the open transition. However, this transition is typically much faster (under 500 ms) than the conventional open transition transfer operation. Voltage and frequency excursions will still occur, but some computer equipment and other sensitive equipment will typically not be affected with a properly designed system. The transfer switch consists of a standard UL approved transfer switch, with mechanical interlocks between the two source contacts that drop the Area EPS source before the DER is connected to supply the load.

- 1) Mechanical interlocks are required between the two source contacts to ensure that one of the contacts is always open. If the mechanical interlock is not present, the protection requirements are as if the switch is a closed transition switch
- 2) As a practical point of application this type of transfer switch is typically used for loads less than 500 kW. This is due to possible voltage flicker problems created on the Area EPS, when the load is removed from or returned to the Area EPS source. Depending upon the Area EPS's stiffness this level may be larger or smaller than the 500-kW level.
- 3) Figure 1 on the previous page provides a typical one-line of this type of installation and shows the required protective elements.

### **Closed Transition (Make-Before-Break) Transfer Switch**

For Closed Transition, the DER is synchronized with the Area EPS prior to the transfer occurring. The transfer switch then parallels with the Area EPS for a short time (500 ms or less) and then the DER and load is disconnected from the Area EPS. This transfer is less disruptive than the Quick Open Transition because it allows the DER a brief time to pick up the load before the support of the Area EPS is lost. With this type of transfer, the load is always being supplied by the Area EPS or the DER.

- 1) As a practical point of application this type of transfer switch is typically used for loads less than 500 kW. This is due to possible voltage flicker problems created on the Area EPS, when the load is removed from or returned to the Area EPS source. Depending upon the Area EPS's stiffness this level may be larger or smaller than the 500-kW level.
- 2) Figure 2 on the following page provides a typical one-line of this type of installation and shows the required protective elements. The closed transition switch must include a separate parallel time limit relay, which is not part of the generation control PLC and trips the generation from the system for a failure of the transfer switch and/or the transfer switch controls.

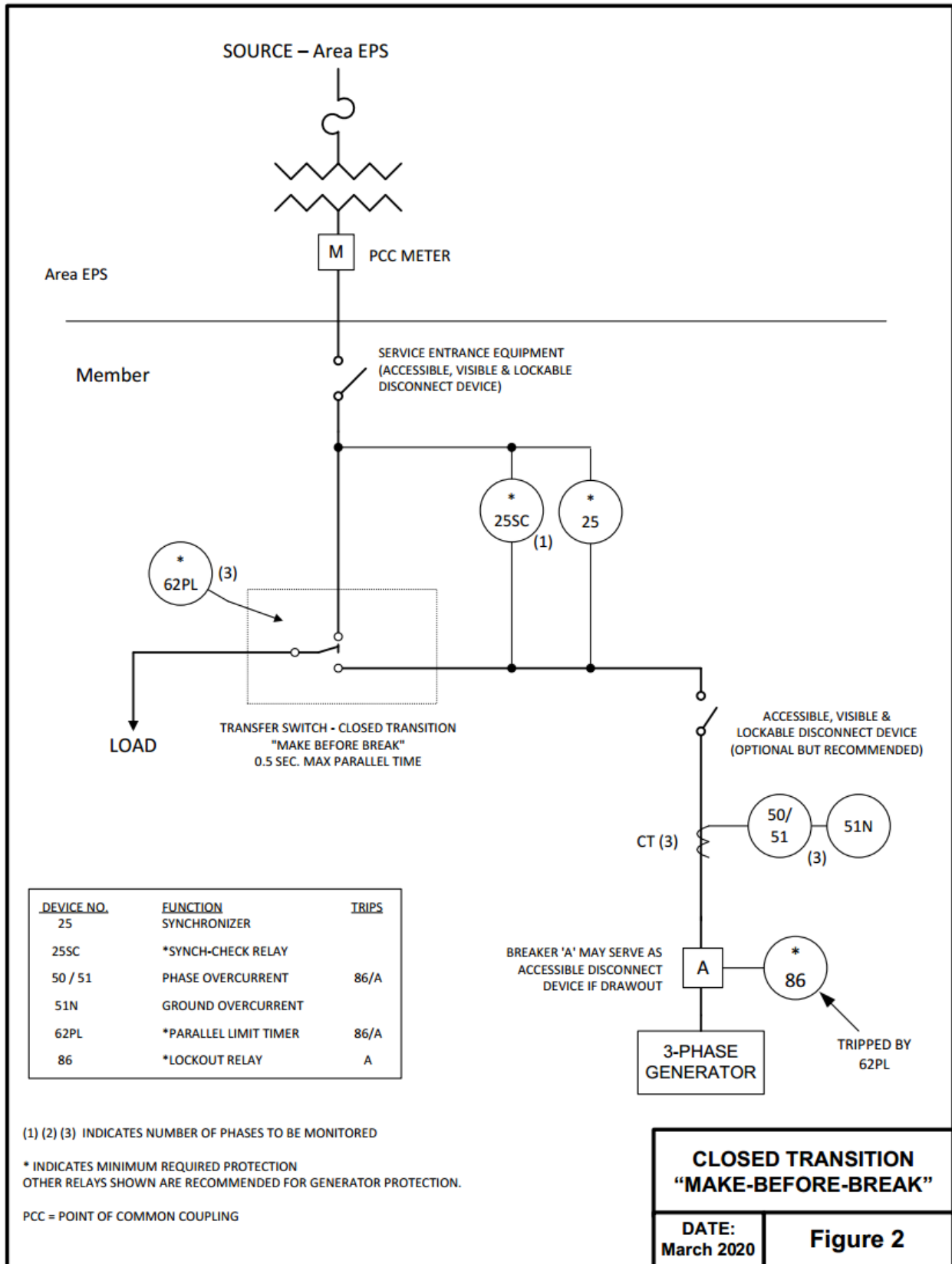

### **Soft Loading Transfer Switch – With Limited Parallel Operation**

For this type of interconnection, the DER is paralleled with the Area EPS for a limited amount of time (generally less than 1-2 minutes) to gradually transfer the load from the Area EPS to the generating DER system. This minimizes the voltage and frequency problems, by softly loading and unloading the DER.

- 1) The maximum parallel operation shall be controlled, via a parallel timing limit relay (62PL). This parallel time limit relay shall be a separate relay and not part of the generation control PLC.
- 2) Protective Relaying is required as described in Section 6 of this document.
- 3) Figure 3 on the following page provide typical one-line diagrams of this type of installation and show the required protective elements.



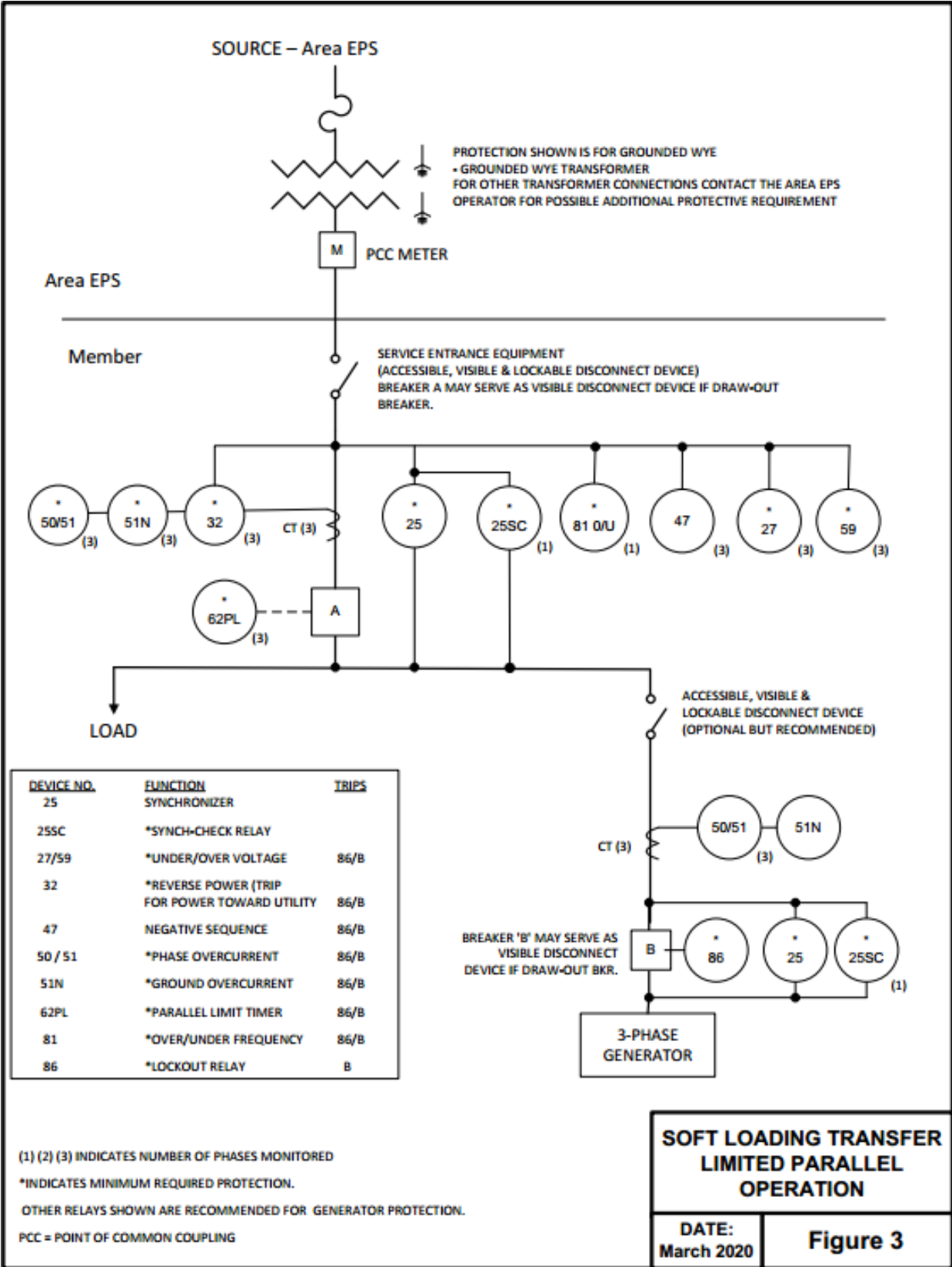

### **Soft Loading Transfer Switch – With Extended Parallel Operation**

The DER is paralleled with the Area EPS in continuous operation. Special design, coordination and agreements are required before any extended parallel operation will be permitted. The Area EPS interconnection study will identify the issues involved.

- 1) Any anticipated use in the extended parallel mode requires special agreements and special protection coordination.
- 2) Protective Relaying is required as described in Section 6 of this document.
- 3) Figure 4 on the following page provides a typical one-line for this type of interconnection. It must be emphasized that this is a typical installation only and final installations may vary from the examples shown due to transformer connections, breaker configuration, etc.

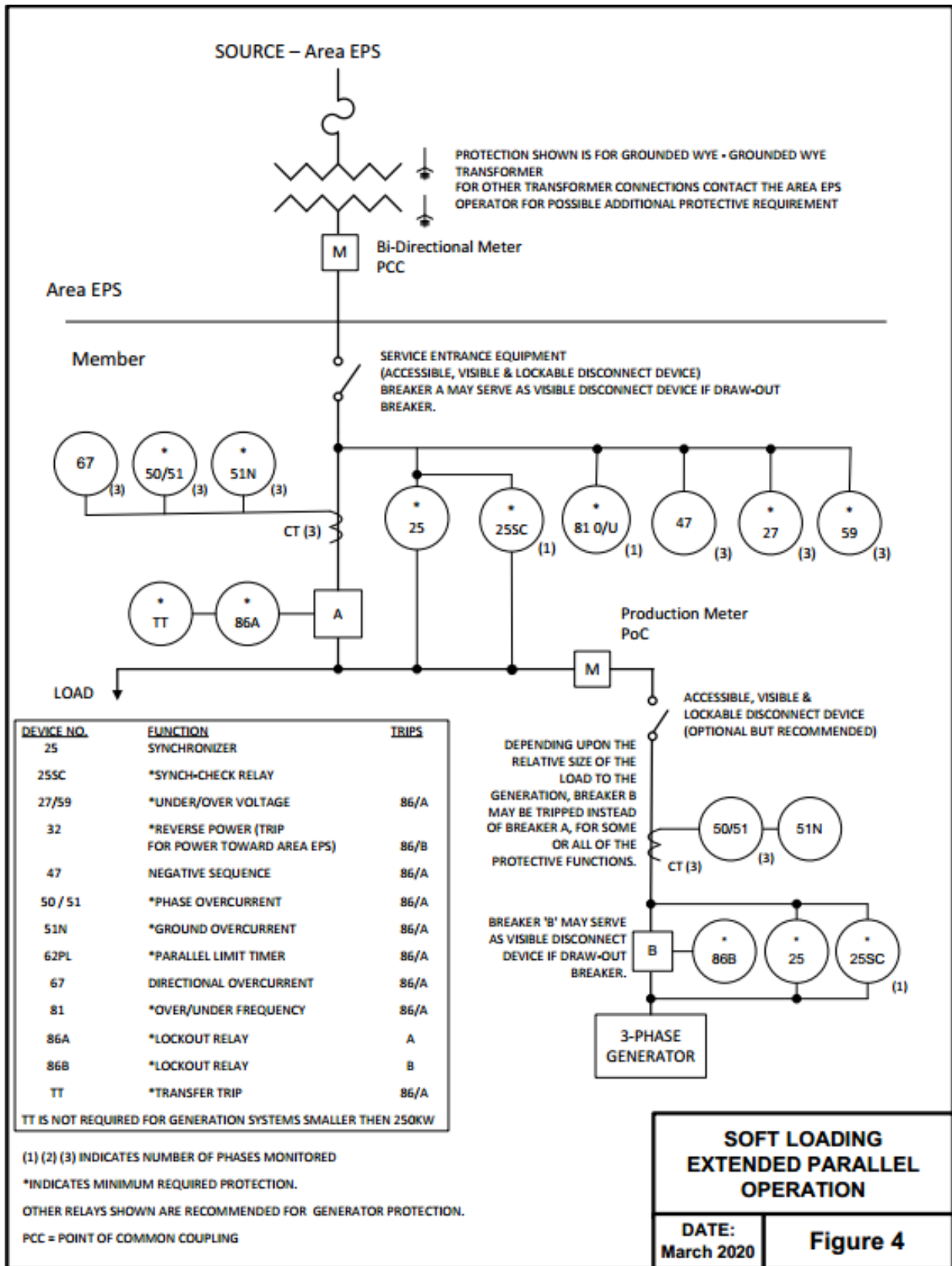

## **Inverter Connection**

An inverter Connection is a continuous parallel connection between the DER and Area EPS. Small generating DER systems may utilize inverters to interface to the Area EPS. Solar, wind and fuel cells are some examples of DER which typically use inverters to connect to the Area EPS. The design of such inverters shall either contain all necessary protection to prevent unintentional islanding, or the Interconnection Customer shall install conventional protection to affect the same protection. All required protective elements for a soft-loading transfer switch apply to an inverter connection. Figure 5 on the following page shows a typical inverter interconnection.

- 1) **Inverter Certification** – Prior to installation, the inverter shall be Type-Certified for interconnection to the electrical power system. The certification will confirm its anti-islanding protection and power quality related levels at the Point of Common Coupling. Also, utility compatibility, electric shock hazard and fire safety are approved through UL listing of the model. Once this Type Certification is completed for that specific model, additional design review of the inverter should not be necessary by the Area EPS Operator.
- 2) For three-phase operation, the inverter control must also be able to detect and separate for the loss of one phase. Larger inverters will still require custom protection settings, which must be calculated and designed to be compatible with the specific Area EPS being interconnected with.
- 3) A visible disconnect is required for safely isolating the DER when connecting with an inverter. The inverter shall not be used as a safety isolation device.
- 4) When banks of inverter systems are installed at one location, a design review by the Area EPS Operator must be performed to determine any additional protection systems, metering or other needs. The issues will be identified by the Area EPS Operator during the interconnection process.

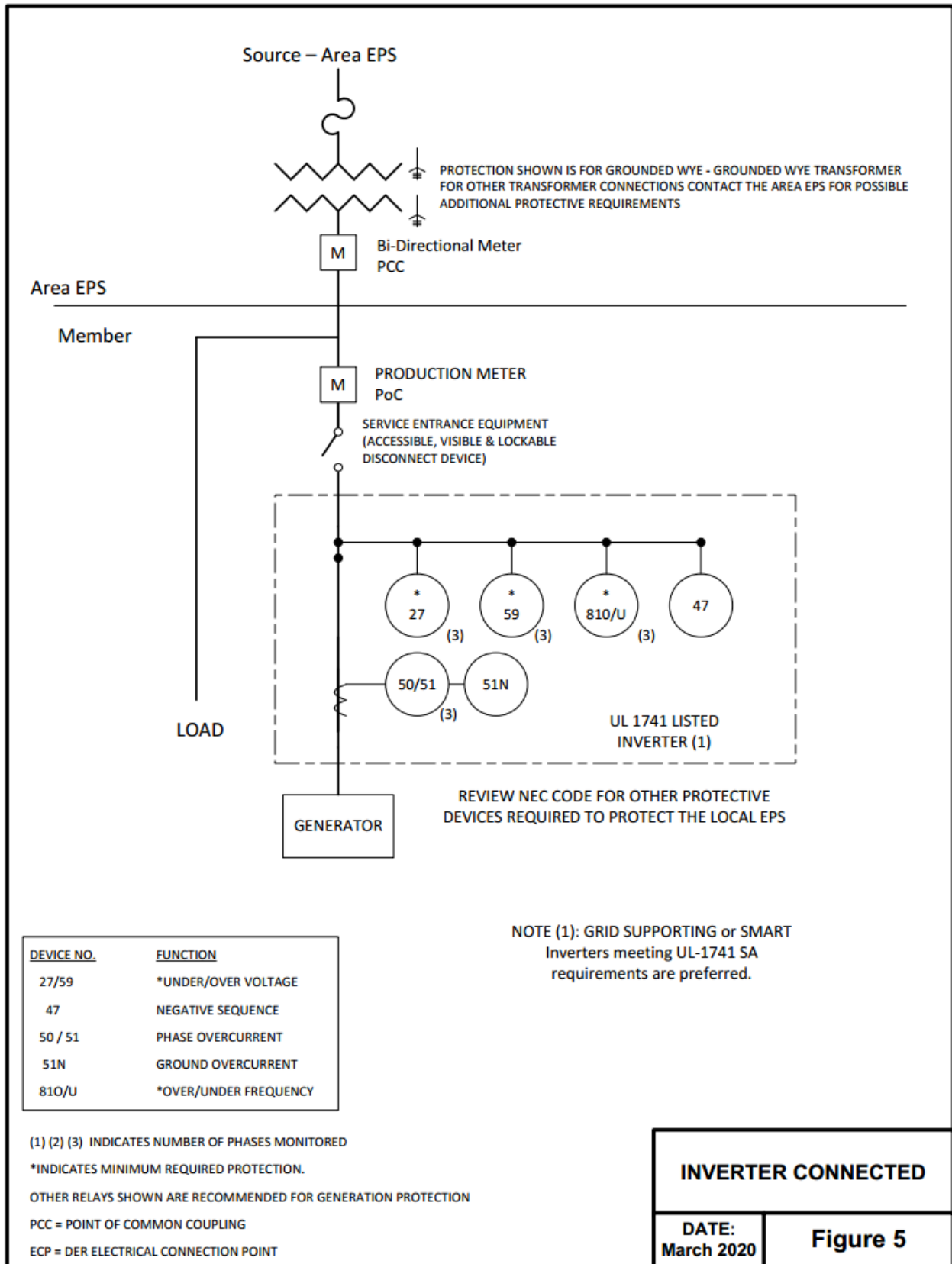

## Appendix B – Relay Functions

Non-Certified installation, depending on the interconnection configuration, are required to provide the appropriate relay function listed in this section. The interconnection types in Appendix A will specify which relay function may be applicable.

Over-current relay (IEEE Device 50/51 or 50/51V) shall operate to trip the protecting breaker at a level to ensure protection of the equipment and at a speed to allow proper coordination with other protective devices. For example, the over-current relay monitoring the interconnection breaker shall operate fast enough for a fault on the customer's equipment, so that no protective devices will operate on the Area EPS. 51V is a voltage restrained or controlled over-current relay and may be required to provide proper coordination with the Area EPS.

Directional Over-Current Relay (IEEE Device 67) This element uses the phase relationship of the voltage and current to determine direction of the fault.

Over-Voltage Relay (IEEE Device 59) shall operate to trip the DER per the requirements of IEEE 1547. See table in Section 5.1.

Under-Voltage Relay (IEEE Device 27) shall operate to trip the DER per the requirements of IEEE 1547. See table in Section 5.1.

Over-Frequency Relay (IEEE Device 81O) shall operate to trip the DER off-line per the requirements of IEEE 1547. See table in Section 5.2.

Under-Frequency Relay (IEEE Device 81U) shall operate to trip the DER off-line per the requirements of IEEE 1547. See table in Section 5.2.

Synch Check Relay (IEEE Device 25 / 25SC) The Area EPS will provide the reference frequency of 60 Hz. The DER control system must be used to match this reference. The protective relaying in the interconnection system will be expected to maintain the frequency of the output of the DER.

Phase Sequence or Phase Balance Detection (IEEE Device 47) Provides protection for rotating equipment from the damaging effects of excessive negative sequence voltage resulting from a phase failure, phase unbalance and reversed phase sequence. This element helps the DER sense loss of source issues on the Area EPS.

Reverse Power Relays (IEEE Device 32) (power flowing from the DER to the Area EPS) shall operate to trip the DER off-line for a power flow to the system with a maximum time delay of 2.0 seconds.

Lockout Relay (IEEE Device 86) is a mechanically locking device which is wired into the close circuit of a breaker or switch and when tripped will prevent any close signal from closing that device. This relay requires that a person manually resets the lockout relay before that device

can be reclosed. These relays are used to ensure that a de-energized system is not reenergized by automatic control action and prevents a failed control from auto-reclosing an open breaker or switch.

Transfer Trip – All DERs are required to disconnect from the Area EPS when the Area EPS is disconnected from its source, to avoid unintentional islanding. A transfer trip system may be required to sense the loss of the Area EPS source for larger DERs which remain in parallel with the Area EPS. When the Area EPS source is lost, a signal is sent to the DER to separate the DER from the Area EPS. The size and type of the DER and the capacity and minimum loading on the Area EPS circuit will dictate the need for transfer trip installation. The Area EPS interconnection process will identify the specific requirements for the proposed DER system.

If multiple Area EPS sources are available, or multiple points of sectionalizing exist on the Area EPS, more than one transfer trip system may be required. The Area EPS interconnection process will identify the specific requirements for the proposed DER system in this situation. For some installations, the alternate Area EPS source(s) may not be utilized except in rare occasions. In this situation, the Interconnection Customer may elect to have the DER locked out when the alternate source(s) are utilized, if agreeable to the Area EPS Operator.

Parallel Limit Timing Relay (IEEE Device 62PL) set at a maximum of 120 seconds for soft transfer installations and set no longer than 500 ms for closed transfer installations, shall trip the DER circuit breaker on limited parallel interconnection systems. Power for the 62 PL relay must be independent of the transfer switch control power.

Minimum Input Relay (IEEE Device 37) is a setting within a digital relay that will trip the DER if the level of energy flow from the Area EPS goes below a set value. This protection system may be used by the DER to detect faults on the Area EPS. Minimum input relaying schemes must be set to trip immediately upon sensing under power levels and must coordinate with the Area EPS. Minimum input relaying is not allowed for DER systems which have the potential for inadvertent energy flow onto the Area EPS.

Table 7 – Summary of Relaying Requirements

Summary of Relaying Requirements								
Type of Interconnection	Over Current (50/51)	Voltage (27/59)	Frequency (81 O/U)	Reverse Power (32)	Lockout (86)	Parallel Limit Timer (62)	Synch Check (25)	Transfer Trip
Certified Inverter Connected < 250 kW	(1)	(1)	(1)	--	(1)	--	(1)	--
Certified Inverter Connected > 250 kW	Yes (2)	Yes (2)	Yes (2)	Yes (2)	Yes (2)	Yes (2)	Yes (2)	Yes (3)
Quick Open Transition Mechanically Interlocked	--	--	--	--	Yes	Yes	Yes	--
Limited Parallel Closed Transition	--	--	--	--	Yes	Yes	Yes	--
Soft Loading Limited Parallel Operations	Yes	Yes	Yes	Yes	Yes	Yes	Yes	--
Soft Loaded Extended Parallel < 250 kW	Yes	Yes	Yes	--	Yes	--	Yes	--
Soft Loaded Extended Parallel > 250 kW	Yes	Yes	Yes	--	Yes	--	Yes	Yes (3)
Extended Parallel > 250 kW	Yes	Yes	Yes	--	Yes	--	Yes	Yes (3)

Note (1): Function is part of a certified inverter.

Note (2): For inverter-based DER that is 250 kW or larger, a breaker and relaying is required for interconnection with the Area EPS.

Note (3): Direct Transfer-Trip is required if the Area EPS determines the proposed DER cannot detect and trip for an Area EPS fault or loss of source supply to the Area EPS within an acceptable time-frame.



## Appendix C – Types of ESS Control Modes

Common types of ESS control modes are listed in this section. Not all possible control modes are identified and many ESS vendors have different names for similar control modes. For clarity between the Area EPS Operator and the Interconnection Customer, it is helpful to identify which control modes the ESS is capable of and is using on the Storage Application using one of the control modes terms below.

### Emergency Power

The emergency power control mode has the ESS only providing energy to the Local EPS during a power outage and not providing energy to the Local EPS in any other situation. This control mode would have the ESS remaining in a charged state until Area EPS was de-energized. Once the Area EPS was not the source of the local EPS, a switch opens isolating the backed-up load from the Area EPS and the ESS would release energy. Upon reenergization of the Area EPS the switch closes the load so it is sourced from the Area EPS. The ESS would cease in all operation for five minutes prior to moving to a state of charging. (See Section 10.3 Enter Service).

Figure 6. Example of Typical One-line Diagram for Emergency Power Control Mode

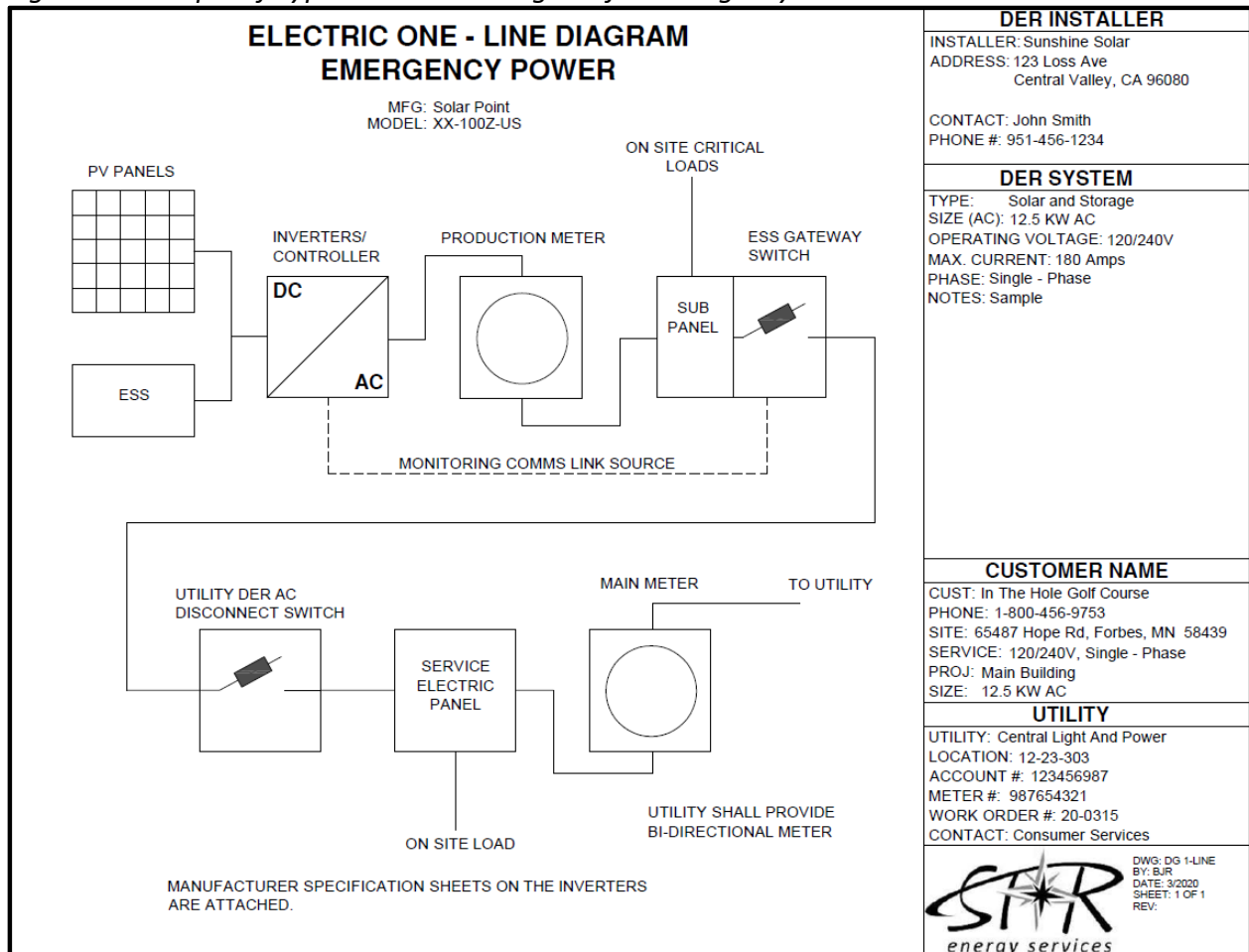

**Demand Reduction Management**

The demand reduction management operating mode has the ESS releasing stored power to reduce the peak demand of the Local EPS. This control mode would have the ESS providing energy to the Local EPS while the Local EPS is also receiving energy from the Area EPS. The ESS would incorporate an energy management system that monitors the load of the Local EPS. When the Local EPS reaches a set demand point, the ESS would release stored power in specified amount. The result is the demand required from the Area EPS would stay at a levelized amount. This type of control mode can be used with electrical services that are billed retail with a volumetric energy component and a demand component. The example one-line of this type of control mode is shown in Figure 6.

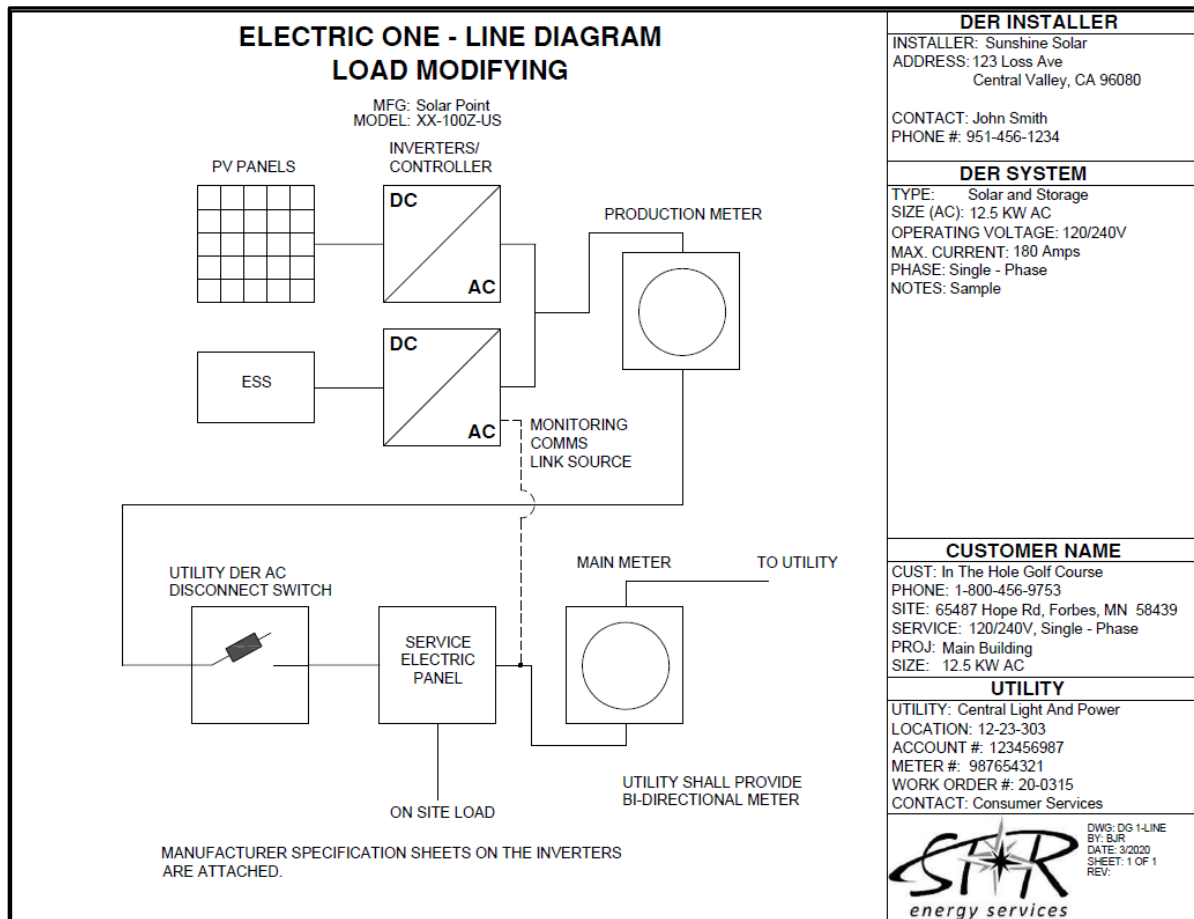

**Non-Exporting, Self-Consumption**

The non-exporting or self-consumption mode incorporates a generating DER, such as a solar system, that would charge the ESS. As the generation exceeds the load, the ESS is charged. When the load exceeds the generation, the ESS can release energy to maintain the power needs of the load is covered, but neither the ESS nor the generating DER (solar) will send power to the Area EPS. This control mode normally includes information from an energy management system. The example one-line of this type of control mode is shown in Figure 7.

### **Time-Of-Use Management**

The time-of-use management control mode has the ESS charging when retail energy prices are low and releasing energy when energy prices are high, offsetting the need for the load to use energy from the Area EPS. This control mode is only beneficial to the interconnection customer if the electric service is on a retail time-of-use rate schedule. The example one-line of this type of control mode is shown in Figure 7.

# Appendix D – Example Diagrams

Figure 8. Example of Typical One-line Diagram of Solar DER

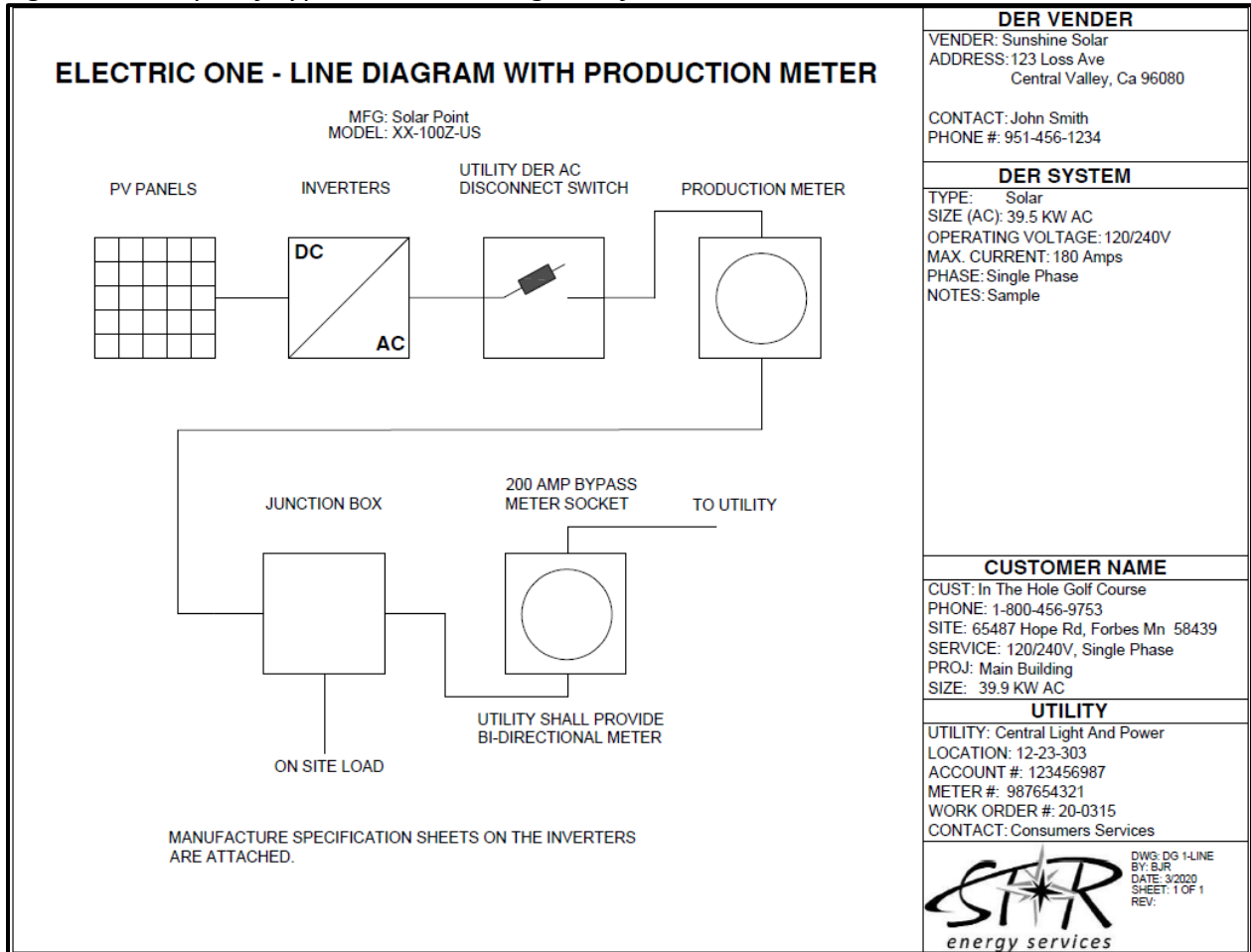

Figure 9. Example One-Line of Solar and ESS with a Common Inverter

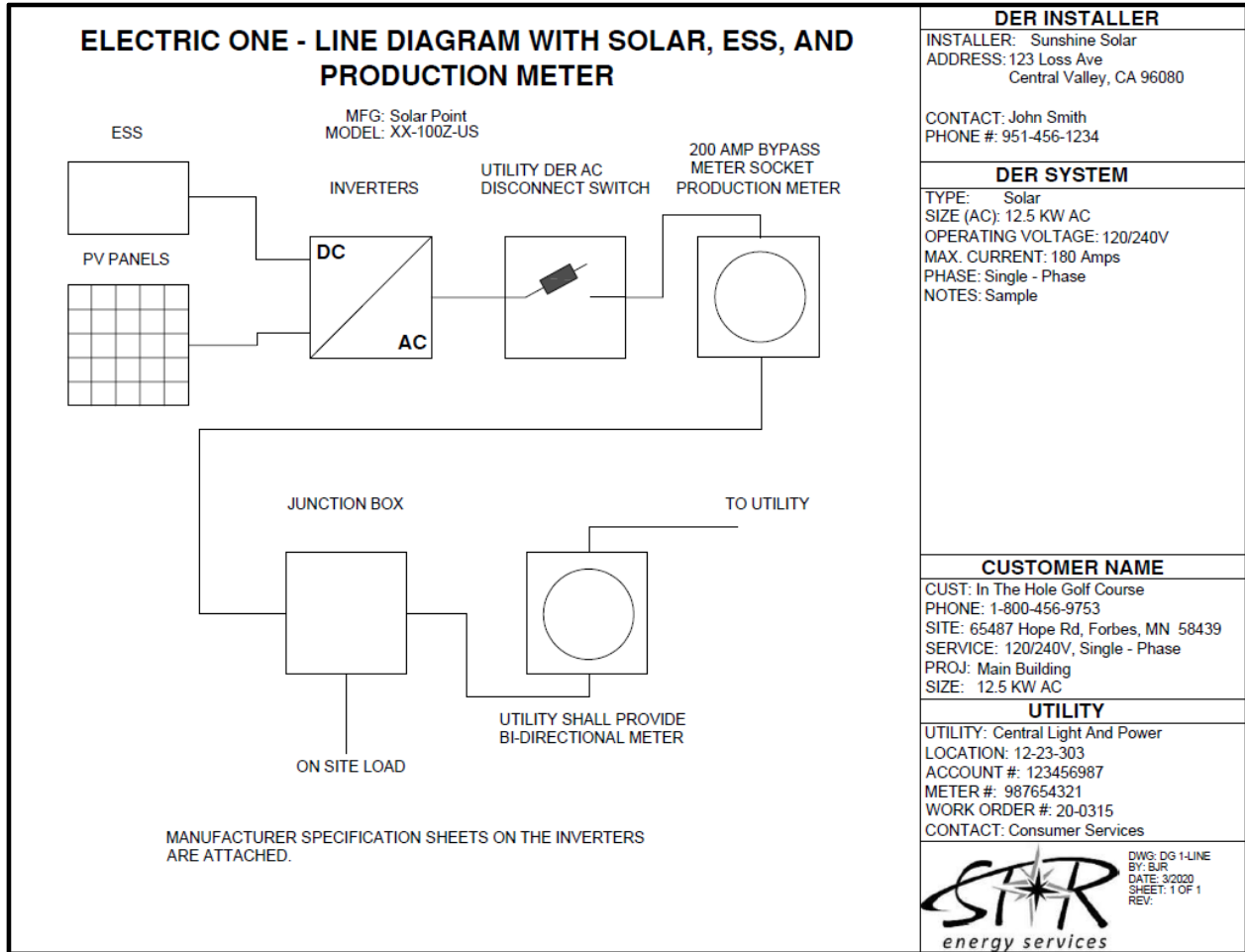

Figure 10. Example One-Line of Solar and ESS with Separate Inverters

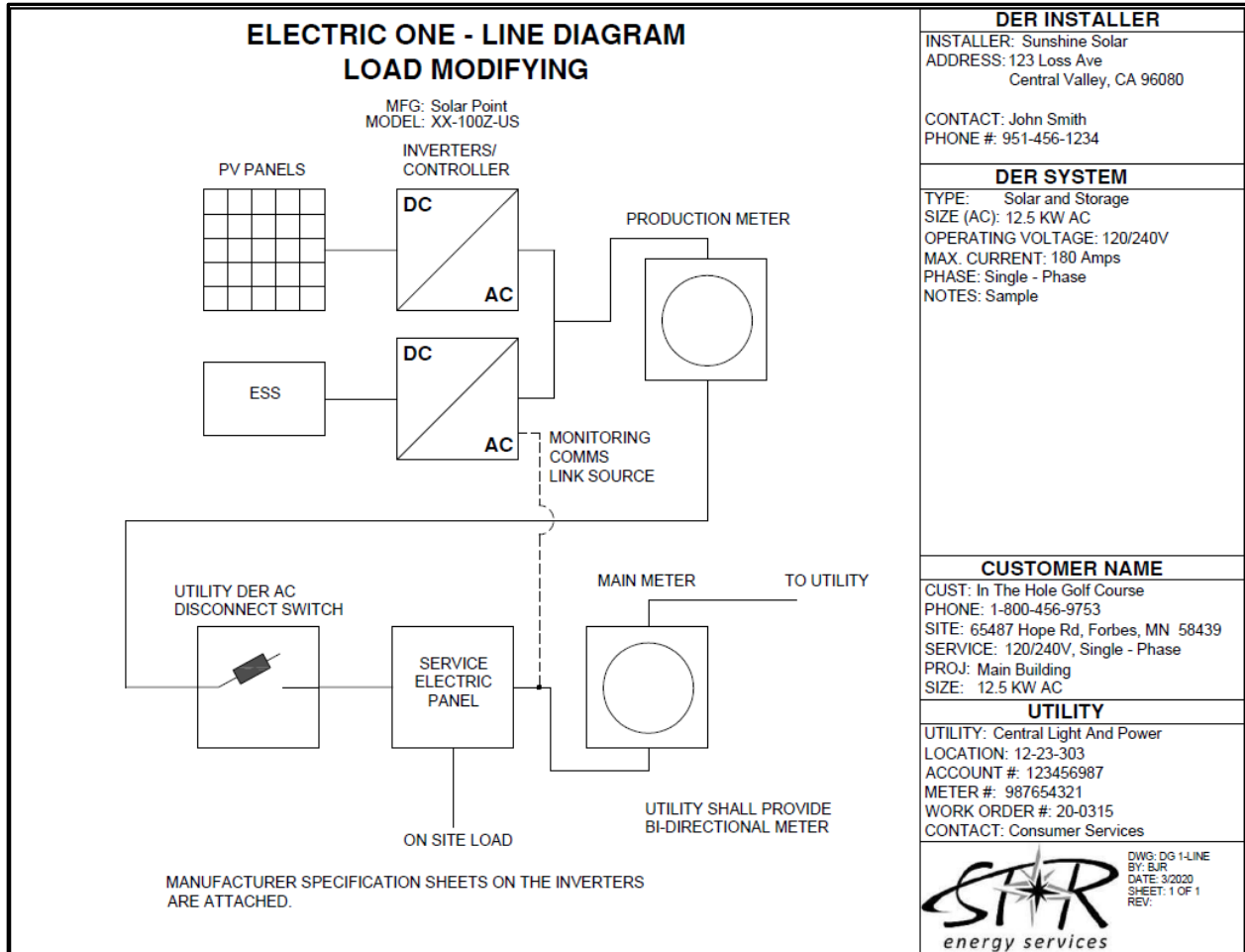
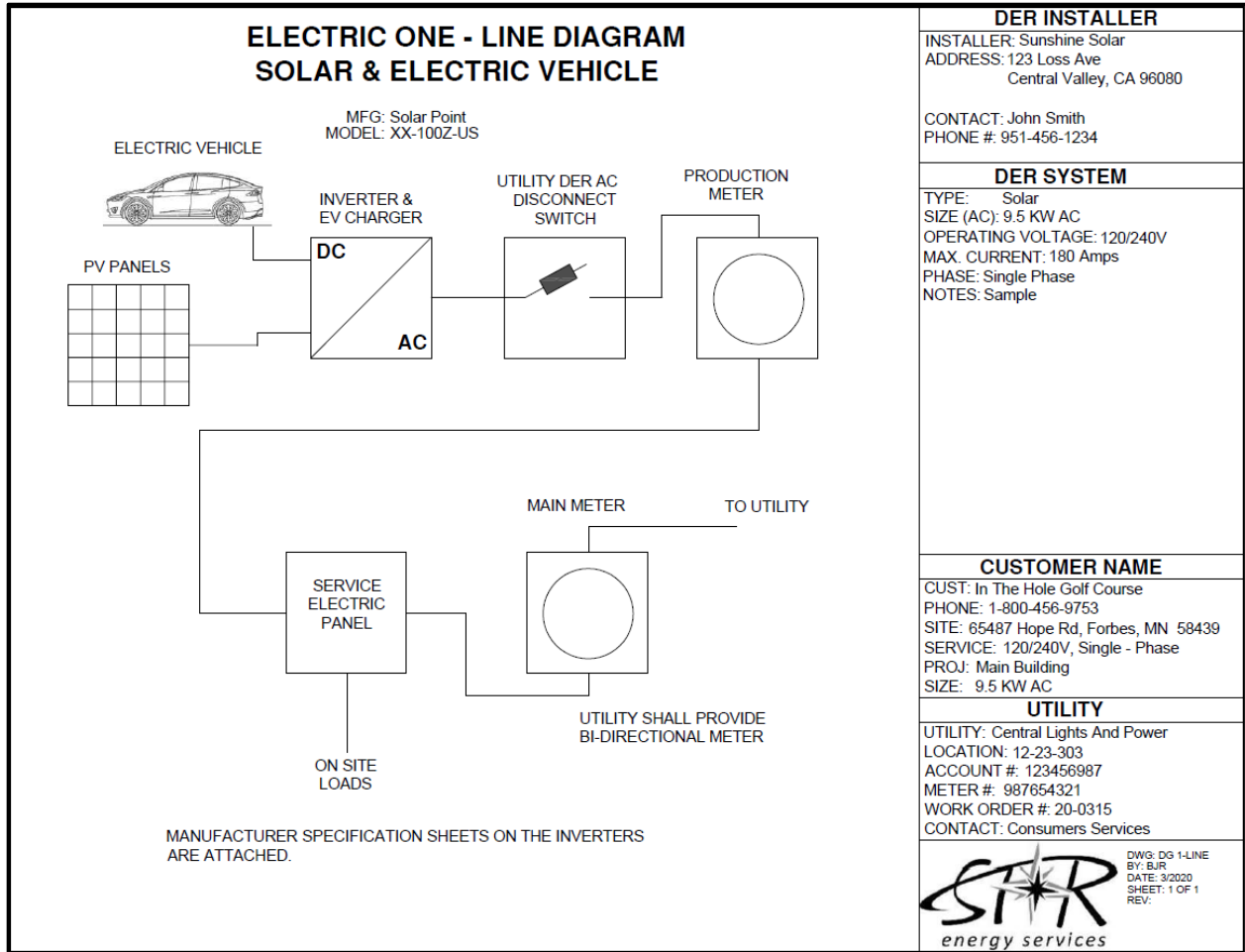

Figure 11. Example One-line for Solar and Electric Vehicle with a Common Inverter



## Appendix E – Example Simplified Process DER Testing Procedure

DER ENERGIZATION PROCEDURE			
Application ID		DER System Size (kW AC)	
Interconnection Customer Name		DER System Type	
Area EPS Operator		Testing Date	

**Visual Verifications**

YES	NO	
		Verify inverter model matches application
		Verify inverter is certified (UL 1741)
		Verify electrical inspection (yellow sticker)
		Verify correct labeling/signage
		Verify the Utility DER AC Disconnect Switch is lockable and has visual open
		Verify DER system installation matches submitted one-line drawing
		Verify metering and Utility DER AC Disconnect Switch are accessible by Area EPS Operator

**Anti-Island Field Test**

**Step 1.** The DER system shall be started in parallel with the distribution system.

**Step 2.** Disconnect the DER from Area EPS by opening the Utility DER AC Disconnect Switch.

YES	NO	
		Production from DER system ceased to operate (no current flowing towards the Area EPS)
or		
		DER system separated from the local load. (A turbine may still spin but no power is being produced to the load.)

**Step 3.** Reconnect the DER system to the Area EPS by closing the Utility DER AC Disconnect Switch.

YES	NO	
		The DER system did not parallel with Area EPS or begin to serve to local EPS load for at least 5 minutes once Utility DER AC Disconnect Switch was closed.

**Step 4.** Disconnect the DER from Area EPS by requesting Area EPS Operator to disconnect the Area EPS at PCC.

YES	NO	
		Production from DER system ceased to operate (no current flowing towards the Area EPS)
or		
		DER system separated from the local load. (A turbine may still spin but no power is being produced to the load.)

Energization Testing Procedure
1



### Open Phase Testing: Multi-phase DER Systems Only

**Step 5.** Disconnect the DER from Area EPS by requesting Area EPS Operator to disconnect the Area EPS at PCC one phase at a time. (If possible, this test can be performed by the Interconnection Customer on the Local EPS at the PoC if only one DER unit.)

YES	NO	
		Phase A: Production from DER system ceased to operate (no current flowing towards the Area EPS)
		Phase B: Production from DER system ceased to operate (no current flowing towards the Area EPS)
		Phase C: Production from DER system ceased to operate (no current flowing towards the Area EPS)

<b>Energization Test Result:</b>	<b>PASS</b>	<b>FAIL</b>
<b>Notes:</b>		
<b>Documented by:</b>		
<b>Testing Attendees:</b>		

Verification of Operational and Protection Settings	
<i>If Certification of Completion was not provided, installer to certify inverter settings.</i>	
I certify that the inverters were programmed so:	
<ul style="list-style-type: none"> <li>• Operating Mode is set to Constant Power Factor with the power factor set to 0.98 absorbing</li> <li>• The Frequency Abnormal Response is set to IEEE 1547-2013 ranges</li> <li>• The Voltage Abnormal Response is set to IEEE 1547-2003 ranges</li> <li>• Dynamic Voltage Support and Volt-Watt is not active (no ride through)</li> </ul>	
Signature:	

IEEE 1547-2003 Voltage Abnormal Response

Shall Trip Function	Default Setting	
	Clearing time (s)	Voltage (per unit of nominal voltage)
UV2	0.16	0.50
UV1	2.0	0.88
OV1	1.0	1.10
OV2	0.16	1.20

IEEE 1547-2003 Frequency Abnormal Response

Shall Trip Function	Default Setting	
	Clearing time (s)	Frequency (Hz)
UF1	0.16	59.3
OF1	0.16	60.5

## Appendix F – DER Alteration Notification

This form is only applicable for installed DER systems that have prior approval from the Area EPS Operator to operate in extended parallel. **Changes to capacity size, type, technology or location should be applied as a new application using either the Simplified or Fast Track application forms.** This form is to inform the Area EPS Operator of changes in inverter, control system and protective device settings or the exchange of “like-for-like” DER equipment. The Area EPS Operator may determine the proposed change requires additional review to ensure the operation of the Area EPS is not detrimentally affected. The Area EPS Operator will notify the listed contact if additional details or steps are required. Contact the DER Coordinator for further information.

General Information		
Original Application ID (If known):		
Customer Account Number:		
Address of Generating Facility:		
City:	State:	Zip Code:
Existing DER System		
Current DER Type <i>(Check all that apply)</i> :		
<input type="checkbox"/> Solar Photovoltaic	<input type="checkbox"/> Wind	<input type="checkbox"/> Energy Storage
<input type="checkbox"/> Combined Heat and Power	<input type="checkbox"/> Solar Thermal	<input type="checkbox"/> Other (please specify)
Aggregate DER Capacity (the sum of nameplate capacity of all generation and storage devices at the PCC):		
$kW_{ac}$		$kVA_{ac}$
Please, in detail, explain the proposed alteration to the DER system: <i>(Example: Existing inverter was replaced with 9.8 kW AC inverter, Solar Edge Model SE-9800-US. Settings remained the same in the inverter.) (Example: Plan to utilize Time-of-Use control mode of ESS. Also updated to firmware v2.3)</i>		
Contact for Additional Questions		
Name:		
Company Name:		
Email:	Phone:	